

**Transportable Refillable Welded Duplex Stainless Steel  
LPG Cylinders-for use in Hot Air Balloons and Hot Air  
Airships.**

## **Contents**

	<b>Foreword</b>
	<b>Introduction</b>
<b>1</b>	<b>Scope</b>
<b>2</b>	<b>Normative references</b>
<b>3</b>	<b>Definitions and symbols</b>
<b>4</b>	<b>Materials</b>
<b>5</b>	<b>Design</b>
<b>6</b>	<b>Construction and Workmanship</b>
<b>7</b>	<b>Testing</b>
<b>8</b>	<b>Acceptance procedure</b>
<b>8</b>	<b>Technical requirements for type approval</b>
<b>10</b>	<b>Marking</b>
<b>11</b>	<b>Certificate</b>

## **Foreword**

This technical code has been prepared in accordance with the requirements of ADR 2003, clause 6.2.3 in the absence of a design code listed in clause 6.2.2 relevant to transportable refillable welded Duplex stainless steel cylinders (pressure receptacles) for use in hot air balloons and hot air airships. This technical code is required as operational requirements dictate that the cylinder design shall minimise empty weight.

## **Introduction**

This technical code calls for the use of substances and procedures that may be injurious to health if adequate precautions are not taken. It refers only to technical suitability and does not absolve the user from legal obligations relating to health and safety at any stage. It has been assumed in the drafting of this technical code that the execution of its provisions is entrusted to appropriately qualified and experienced people.

## **1 Scope**

This technical code specifies minimum requirements concerning material, design, construction and workmanship, type approval procedure and production testing of transportable refillable welded steel Liquefied Petroleum Gas (LPG) cylinders of water capacity from 0,5l up to and including 150l exposed to ambient temperatures for the purpose of providing fuel for burners in hot air balloons and hot air airships.

The pressure shell of the receptacle is fabricated from two torispherical heads circumferentially welded to a longitudinally welded central cylindrical section. Off-take bosses are welded in the upper head of the pressure shell. Shrouds and guards are welded to both the upper and lower heads.

This type of cylinder is designed to be fitted with a pressure relief device and padded, water resistant, protective cover. In addition to standard LPG cylinder markings, the cylinders are marked 'For use in hot air balloons only'.

This Technical code is designed to address both terrestrial transportation and airworthiness criteria.

## 2. Normative references

This Technical code incorporates by dated or undated reference, provisions from other publications. These normative references are cited at the appropriate places in the test and the publications are listed thereafter. For dated references, subsequent amendments to or revisions of any of these publications apply to this Technical code only when incorporated in it by amendment or revision. For undated references the latest edition of the publication referred to applies.

- EN 287-1, *Approval testing of welders-Fusion Welding - Part 1: Steels.*  
EN 288-3, *Specification and approval of welding procedures for metallic materials-Part 3: Welding procedure tests for the arc welding of steels.*
- EN 876, *Destructive tests on welds in metallic materials - Longitudinal tensile test on weld metal in fusion welded joints.*
- EN 895, *Destructive tests on welds in metallic materials - Transverse tensile test.*
- EN 910, *Destructive tests on welds in metallic materials - Bend tests.*  
EN 970, *Non-destructive examination of fusion welds - Visual Examination.*  
EN 1289, *Non-destructive testing of welds-penetrant testing of welds-Acceptance levels.*
- EN 1321, *Destructive tests on welds in metallic materials - Macroscopic and microscopic examination of welds.*
- EN 1435, *Non-destructive examination of welds - Radiographic examination of welded joints.*
- EN 10002-1, *Metallic materials - Tensile testing - Part 1: Method of test.*  
EN 25817, *Arc Welded joints in steel -Guidance on quality levels for imperfections (ISO5817:1992)*
- EN 10028-7, *Specification for flat products made of steels for pressure purposes. Stainless steels.*
- EN13953, *Pressure relief valves for transportable refillable cylinders for Liquefied Petroleum Gas (LPG).*
- BS 3379, *Flexible polyurethane cellular materials for load bearing applications - Specification.*

BS EN 10272:2000, *Stainless steel bars for pressure purposes.*

Euronorm 12-55, *Bend tests for steel sheet and strip less than 3 mm thick.*

Euronorm 103-71, *Micrographic determination of the ferritic or austenitic grain size of steels.*

ISO 2504: 1973, *Radiography of welds and viewing conditions for films Utilisation of the recommended patterns of image quality indications (I.Q.I.).*

Council Directive 1999/36/EC- The Transportable Pressure Equipment Directive (TPED)

ADR, European Agreement Concerning the International Carriage of Dangerous Goods by Road.

## 3. Definitions and symbols

### 3.1 Definitions

For the purposes of this technical code the following definitions apply

#### 3.1.1 yield stress

The upper yield strength,  $R_{eh}$ , or, for steels that do not exhibit a defined yield, the 0,2% proof stress (non-proportional elongation),  $R_p$  (see EN 10002-1).

#### 3.1.2 competent body

A person or corporate body defined by a national authority, which by combination of appropriate qualifications, training, experience and resources is able to make objective judgements on a subject. In this technical code a competent body is a Notified or Approved Body as defined by the TPED.

#### 3.1.3 cold-forming

A final deformation treatment at ambient temperature given to the prefabricated cylinder, known as the preform, which results in a permanent increase in material strength.

### 3.2 Symbols

a	Calculated minimum thickness, in millimetres, of the cylindrical shell.
A	Percentage elongation after fracture
b	Calculated minimum thickness, in millimetres, of the end of the cylinder
C	Shape factor (see table 1)
D	Outside diameter, in millimetres, of the cylinder as given in the design drawing
$D_p$	Outside diameter in millimetres of a bend tests former
h	Height, in millimetres, of the cylindrical part of the end
H	Outside height, in millimetres, of the domed part of the end
J	Stress reduction factor
L	Length in millimetres of the cylinder
$L_o$	Original gauge length, of the test piece in millimetres, in accordance with EN 10002-1
n	Ratio of diameter of bend test former to the thickness of the test piece
$P_c$	Calculation pressure, in bar gauge ( $1 \text{ bar} = 10^5 \text{ Pa} = 10^5 \text{ N/mm}^2$ ), used to calculate the minimum required thickness of the cylindrical shell and ends
$P_b$	Maximum pressure, in bar gauge, attained during the burst test
$P_t$	Actual test pressure, in bar gauge, applied to the cylinder by the manufacturer
$P_{tmin}$	Minimum permissible test pressure, in bar gauge
r	Inside Knuckle radius, in millimetres, of the end
R	Inside dishing radius, in millimetres, of the end
$R_g$	Guaranteed tensile strength

$R_o$	Minimum value of yield stress in Newtons per square millimetre, guaranteed by the cylinder manufacturer for the finished cylinder (See Note)
$R_m$	Actual value of tensile strength, in Newtons per square millimetre

Note For cold-formed cylinders the minimum value guaranteed by the manufacturer refers only to the cylindrical part of the cylinder.

## 4. Materials.

- 4.1 Materials for cylindrical wrapper and end pressings shall be Duplex stainless steel according to EN 10028-7.
- 4.2 Materials for the cylinder bosses shall be of weldable and compatible stainless steel according to BS EN 10272.
- 4.3 Materials for the cylinder guards and internal fittings shall be of weldable and compatible stainless steel.
- 4.4 All parts of the cylinder shall be made of compatible material and be compatible with liquid propane.
- 4.5 The welding consumables shall be such that they are capable of giving consistent welds with minimum tensile strength at least equal to that specified for the parent materials in the finished cylinder.
- 4.6 The cylinder manufacturer shall have certificates of the ladle analysis and mechanical properties of the stainless steel supplied for the construction of the pressure retaining parts of the cylinder.
- 4.7 The manufacturer shall maintain a system of identification for the materials used in the fabrication in order that all materials for pressure parts in the completed cylinder can be traced to its origin.
- 4.8 The protective foam covering the main body of the cylinder shall be a minimum of 25 mm thick and to a minimum specification BS3379, classification B-A/S-130-160. The protective foam shall be completely covered with a water resistant outer layer manufactured from a high tenacity fabric such as Cordura.

## 4.9 Heat Treatment

For cylinders subjected to cold-forming processes, heat treatment of the pre-form component part is not required. Cold-formed cylinders shall not be subjected to any subsequent heat treatment or to additional heat application, such as welding.

## 5. Design

### 5.1 General requirements

- 5.1.1 The calculation of the wall thickness of the pressure parts to resist the internal pressure shall be related to the yield stress of the material.
- 5.1.2 For calculation purposes, the value of the yield stress,  $R_o$ , is limited to  $0,85R_G$ .
- 5.1.3 The calculation pressure  $P_c$ , used in the calculation of the cylinder wall thickness, shall be
$$P_c = P_{tmin} = 30 \text{ bar.}$$
- 5.1.4 A fully dimensional drawing including the specification of the material shall be produced.

## 5.2 Cylindrical shell thickness.

The wall thickness of the cylindrical shell shall be not less than that calculated using the formula:

$$a = P_c D \div \left[ \frac{18R_0 J}{4/3} + P_c \right] \quad \text{The value of J shall be 0.9}$$

The minimum wall thickness adopted by the cylinder manufacturer will be confirmed by the tests specified in 8.

## 5.3 Design of ends concave to pressure

5.3.1 The shape of the torispherical ends of the cylinders shall be such that the following conditions are fulfilled:

$$R \leq D; r \geq 0,1 D; h \geq 4b \text{ (see Figure 1).}$$

5.3.2 The wall thickness of the ends shall be not less than that calculated using the formula:

$$b = P_c D C \div \left[ \frac{20R_0}{4/3} + P_c \right]$$

In this formula, C is a shape factor, the value of which depends on the ratio H/D. The value of C shall be obtained from Table 1 and the graphs in Figure 2 and Figure 3.

The graph in Figure 2 details the value C in relation to the ratio of b/D.

Table 1 - Relationship between H/D and Shape Factor C

H/D	C	H/D	C
0,25	1,000	0,38	0,612
0,26	0,931	0,39	0,604
0,27	0,885	0,40	0,596
0,28	0,845	0,41	0,588
0,29	0,809	0,42	0,581
0,30	0,775	0,43	0,576
0,31	0,743	0,44	0,572
0,32	0,713	0,45	0,570
0,33	0,687	0,46	0,568
0,34	0,667	0,47	0,566
0,35	0,649	0,48	0,565
0,36	0,633	0,49	0,564
0,37	0,621	0,50	0,564

NOTE: Intermediate values may be obtained by linear interpolation.

## 5.4 Minimum wall thickness

**5.4.1** The minimum wall thickness of the cylindrical shell  $a$ , and of the end  $b$ , shall not be less than the value derived from any of the following formulae:

for  $D < 100$  mm:

$$a_{\min} = b_{\min} = 1,1 \text{ mm} \quad (1)$$

for  $100 \leq D \leq 150$  mm:

$$a_{\min} = b_{\min} = 1,1 + 0,008(D - 100) \text{ mm} \quad (2)$$

for  $D > 150$  mm:

$$a_{\min} = b_{\min} = (D/R_o) + 0,7 \text{ mm (with an absolute minimum of 1,5 mm).}$$

Apart from the requirements of **5.3** and **5.4**, any cylindrical part integral with an end shall, except as qualified by **5.4.2**, also satisfy the requirements in **5.2** for the cylindrical shell.

**5.4.2** The equation in **5.2** is not applicable where the length of the cylindrical portion of the cylinder, measured between the beginning of the domed parts of the two ends, is not more than  $\sqrt{2bD}$ . In this case the wall thickness shall be not less than that of the domed part (see **5.3.2**).

## 5.5. Design of Openings

**5.5.1** Each opening in the cylinder shall be reinforced, either by a valve boss or pad, of weldable and compatible stainless steel, securely attached by welding and so designed as to be of adequate strength and to result in no harmful stress concentrations. This shall be confirmed a fatigue test in accordance with 7.8.

**5.5.2** The welds of the openings shall be clear of circumferential joints.

## 6 Construction and workmanship

### 6.1 Welding qualification

**6.1.1** The manufacturer shall have the technical capability, have at his disposal all appropriate means, and qualified personnel to carry out the manufacture of cylinders.

**6.1.2** The manufacturer, with the agreement of a competent body, before proceeding with the production of a given design of cylinder, shall approve the welding procedures to EN 288-3 and welders to EN 287-1, for all welding associated with the pressure envelope including the non-pressure containing parts. Records of such approvals shall be retained by the manufacturer.

**6.1.3** Welding procedure approval tests shall be made in such a manner that the welds shall be representative of those made in production.

**6.1.4** Welders shall have passed the approval tests for the specific type of work and procedure concerned.

## **6.2 Plates and pressed parts**

**6.2.1** Before assembly, the pressure parts of the cylinders shall be visually examined in accordance with EN970 for uniform quality and freedom from defects which may ultimately affect the cylinder integrity. The surface of the metal and in particular the inner wall shall be clean, dry and free from oxidation products, corrosion and scale.

**6.2.2** The minimum thickness of the pressure parts shall be checked against the design drawing.

## **6.3 Welded joints**

**6.3.1** The welding of the longitudinal and circumferential joints shall be by a fully mechanized or automatic process to provide consistent and reproducible quality of welds.

**6.3.2** The longitudinal joint, of which there shall be no more than one, shall be the butt welded type.

**6.3.3** Circumferential joints, of which there shall be no more than two, shall be butt welded, or butt welded with one member offset to form an integral backing strip, i.e. joggled (see Figure 4).

**6.3.4** Before the cylinders are closed, longitudinal welds shall be visually examined from both sides in accordance with EN 970. The longitudinal welds shall be assessed against the requirements of EN25817-Level C. Permanent backing strips shall not be used with longitudinal welds.

**6.3.5** The fusion of the welded metal with the parent metal shall be smooth and free from overlapping, undercutting or abrupt irregularity. There shall be no cracks, notching or porous patches in the welded surface and the surface adjacent to the weld. The welded surface shall be regular and even without concavity.

**6.3.6** Butt welds and joggled butt welds shall have full penetration. The excess thickness shall not exceed one-fourth of the width of the weld.

**6.3.7** The welds of the pressure parts shall be liquid penetrant inspected against the requirements of EN1289- Acceptance Level 1. The penetrant materials shall be chloride free.

## **6.4 Tolerances**

### **6.4.1 Out of roundness**

The out of roundness of the cylindrical shell shall be limited so that the difference between the maximum and the minimum outside diameter in the same cross section is not more than 2 % of the mean of these diameters.

### **6.4.2 Straightness**

Unless otherwise shown on the manufacturer's drawing, the maximum deviation of the cylindrical part of the shell from a straight line shall not exceed 0,3 % of the cylindrical length.

### **6.4.3 Verticality**

When the cylinder is standing on its base, the cylindrical shell and the axis of the top openings shall be vertical to within 1,5°.

## **6.5 Non pressure containing attachments**

**6.5.1** Where non pressure containing attachments are to be attached to the cylinder by welding, such attachments shall be made of weldable and compatible steel (see **4.2**).

**6.5.2** Attachments shall be designed to permit inspection of welds, which shall be clear of longitudinal and circumferential joints, and so designed as to avoid trapping water.

**6.5.3** Where a footing is fitted, it shall be of adequate strength to provide stability and be attached so that it does not prevent inspection of any pressure containing welds. Any footing shall be suitably drained and the space enclosed by the footing suitably ventilated, e.g. by means of openings.

## **6.6 Valve protection**

Valves shall be effectively protected from damage which could cause the release of gas by a protective shroud. The design of the shroud shall be verified by a drop test as specified in **7.10**.

## **6.7 Closure of openings**

Apertures in finished cylinders shall be either:

- a) fitted with a plug of suitable non-absorbent material; or
- b) fitted with the appropriate valve or fitting; to protect the thread from damage and to prevent entry of moisture into the cylinder.

## **6.8 Cylinder Cover**

The cylinder shall be fitted with a water resistant padded cover of foam or similar material not less than 25 mm thick as specified in **4.8**.

## **6.9 Pressure Relief Device**

The cylinder shall be fitted with a pressure relief device to EN13953. The nominal set pressure shall be 26 Bar. The minimum required discharge capacity shall be 7.67m<sup>3</sup>/min.

# **7 Testing**

## **7.1 Mechanical testing**

### **7.1.1 General requirements**

**7.1.1.1** Where not covered by the requirements contained in this clause, the mechanical tests are to be carried out in accordance with the following European Standards and Euronorms:

a) parent material:

EN 10002-1: in the case of the tensile test;

Euronorm 12-55: in the case of the bend test.

b) welded test specimens tested in accordance with **7.1.2**.

**7.1.1.2** All the mechanical tests for checking the properties of the parent metal and welds of the pressure containing shells of the gas cylinders shall be carried out on test specimens taken from cylinders after all manufacturing processes, including cold-forming, have been completed.

## 7.1.2 Types of test and evaluation of test results

### 7.1.2.1 Tests

Each sample cylinder shall be subjected to the following tests on test specimens taken from the places shown in Figure 5.

1 tensile test (in accordance with EN 876)	parent metal of cylindrical part in the longitudinal direction, a), or, if this is not possible, in a circumferential direction
1 tensile test (in accordance with EN 876)	parent metal from one dished end, b)
1 tensile test (in accordance with EN 895)	perpendicular to the longitudinal weld, c)
1 tensile test (in accordance with EN 895)	perpendicular to the circumferential weld, d)
1 bend test (in accordance with EN 910)	on the topside of longitudinal weld, e)
1 bend test (in accordance with EN 910)	on the underside of the longitudinal weld, f)
1 bend test (in accordance with EN 910)	on the topside of the circumferential weld, g)
1 bend test (in accordance with EN 910)	on the underside of the circumferential weld, h)
1 macro test (in accordance with EN 1321)	on a randomly selected location on the circumferential weld
1 macro test (in accordance with EN 1321)	on a randomly selected welded boss

- Test pieces which are not sufficiently flat shall be flattened by cold pressing.
- In all bend test specimens containing a weld, the weld shall be machined flush with the parent metal surface.

### 7.1.2.2 Tensile Test

#### 7.1.2.2.1 Tensile test on parent metal

**7.1.2.2.1.1** The procedure for carrying out the tensile test is that given in the appropriate European Standards in accordance with 7.1.1.1.

The two faces of the test specimen representing the inside and outside walls of the cylinder respectively shall not be machined.

**7.1.2.2.1.2** The values obtained for yield stress, tensile strength and elongation shall be not less than those guaranteed by the cylinder manufacturer and in no case less than those given in the material specification.

#### 7.1.2.2.2 Tensile test on welds

**7.1.2.2.2.1** The tensile test perpendicular to the weld (see EN 895) shall be carried out on a test specimen having a reduced cross section 25 mm in width for a length extending up to 15 mm beyond the edges of the weld (see Figure 8). Beyond this central part the width of the test specimen shall increase progressively.

**7.1.2.2.2.2** The tensile strength value obtained,  $R_m$ , shall not be less than that guaranteed by the cylinder manufacturer,  $R_g$ , and in no case less than those given in the material specification, irrespective of where the fracture occurs in the cross section of the central part of the test specimen.

### **7.1.2.3 Bend test**

**7.1.2.3.1** The procedure for carrying out a bend test is given in EN 910. The bend test shall be 25 mm in width. The mandrel shall be placed in the centre of the weld while the test is being performed (see Figure 6).

**7.1.2.3.2** Cracks shall not appear in the test specimen when it is bent round a mandrel such that it has been bent through 180° (see Figure 6).

**7.1.2.3.3** The ratio  $n$  between the diameter of the mandrel  $D_p$  and the thickness of the test specimen  $a$  shall not exceed 4.

### **7.1.2.4 Macro test on circumferential welds and welded bosses.**

The macro examination, carried out in accordance with EN 1321 of a full transverse section of the welds, shall show complete fusion and complete penetration as specified in 7.4.5. In addition, the cross sections of the welded bosses shall be free from any assembly faults or unacceptable defects, as defined by 7.4.5. In case of doubt, a microscopic examination shall be made of the suspect area.

## **7.2 Burst test under hydraulic pressure**

### **7.2.1 Test conditions**

**7.2.1.1** If it is proposed to apply markings (in accordance with clause 10) on the section of the cylinder subjected to pressure, then cylinders to be tested shall be similarly marked.

**7.2.1.2** The burst test under hydraulic pressure shall be carried out with equipment which enables the pressure to be increased gradually until the cylinder bursts. The pressure at which the cylinder bursts shall be recorded.

### **7.2.2 Minimum test requirements**

#### **7.2.2.1 Bursting pressure**

The measured bursting pressure  $P_b$  shall not under any circumstances be less than 9/4 of the calculation pressure  $P_c$ , and not less than 50 bar.

#### **7.2.2.2 Type of fracture**

- a) The burst test shall not cause any fragmentation of the cylinder.
- b) The main fracture shall not show any brittleness, i.e. the edges of the fracture shall not be radial but shall be at an angle to a diametrical plane and display a reduction of area throughout their thickness.
- c) The fracture shall not reveal a visible defect in the metal, e.g. lamination.

## **7.3 Pressure test**

**7.3.1** The pressurisation medium shall normally be a liquid. A gas may be used provided that appropriate safety precautions are taken.

**7.3.2** The test pressure shall be 30 Bar. In any case, the membrane stress within the wall of the cylinder shall not exceed 77% of the minimum yield stress of the material (as stated in the material standard) during the test.

**7.3.3** The pressure in the cylinder shall increase gradually until the test pressure is reached.

**7.3.4** The cylinder shall remain under the test pressure long enough, at least 30s, to make it possible to establish that no leak can be observed.

**7.3.5** After the test the cylinder shall show no signs of permanent deformation.

**7.3.6** Any cylinder tested which does not pass the test shall be rejected.

**7.3.7** The inside of the cylinder shall be dried when the test is completed.

## **7.4 Radiographic examination**

### **7.4.1. General**

Radiographic examination shall conform to the techniques specified in **7.4.3**, **7.4.4** and **7.4.5**.

### **7.4.2 Radiographic requirements**

a) Radiography shall be carried out on the circumferential and longitudinal welds (see Figure 7) of the first production cylinder after a change in type or size of cylinder or the welding procedure (including machine setting), or after a break in production exceeding 4 h.

b) In addition to the requirements of a), one cylinder out of every 250 production cylinders shall have the junction of the longitudinal and circumferential welds radiographed as indicated in Figure 7.

c) Where more than one welding machine is used for production, the above procedures shall apply to each such machine.

**7.4.3** Radiography of welds shall be carried out in accordance with EN1435, class B.

**7.4.4** Assessment of the weld radiographs shall be based on the original films in accordance with the practice recommended in clause 6 of ISO 2504:1973.

**7.4.5** The following imperfections as defined in EN 25817 are not permitted:

- cracks, inadequate welds or lack of penetration or lack of fusion of the weld;
- any elongated inclusion or any group of rounded inclusions in a row where the length represented over a weld length of  $12a$  is greater than 6 mm;
- any gas pore measuring more than  $(a/3)$  mm;
- any gas pore measuring more than  $(a/4)$  mm, which is 25 mm or less from any other gas pore;
- gas pores over any 100 mm length, where the total area, in mm<sup>2</sup>, of all the figures is greater than  $2a$

## **7.5 Examination of welding non pressure containing attachments.**

For the examination of welding of non-pressure containing attachments, radiographic or macro examinations shall be carried out on at least one cylinder out of every 250 production cylinders. The examination may be carried out on samples taken from cylinders corresponding to non-destructive tests specified in **8.2**.

## **7.6 Unacceptable defects radiographic or macro examination.**

Should any of the radiographic or macro examinations show any unacceptable defects, production shall be stopped and every cylinder welded since the preceding acceptable radiographic or macro examination shall be set aside until it is demonstrated that these cylinders are satisfactory either by radiographic or macro or other appropriate means.

Production shall not be restarted until the cause of the defect has been established and rectified, and the starting up test procedure as specified in **7.4.2 a)** has been repeated.

## **7.7 Examination of the surface of the weld**

**7.7.1** This examination, according to EN 970, is carried out when the weld has been completed. The welded surface examined shall be well illuminated, and shall be free from grease, dust, scale residue or protective coating of any kind.

**7.7.2** The weld shall comply with the requirements of **6.3**.

## **7.8 Fatigue test**

**7.8.1** For the purpose of this test, a cylinder which is guaranteed by the manufacturer to be representative of the design and which include all marking (in accordance with clause 10) shall be filled with a non-corrosive liquid and subjected to successive reversals of hydraulic pressure.

**7.8.2** The test shall be carried out at an upper cyclic pressure equal to the test pressure. The cylinder shall be subjected to 12000 cycles without failure.

The value of the lower cyclic pressure shall not exceed 10% of the upper cyclic pressure.

The frequency of reversals of pressure shall not exceed 0,25 Hz (15 cycles/min).

The temperature measured on the outside surface of the cylinder shall not exceed 50 °C during the test.

**7.8.3** After the test, the cylinder ends and the welds shall be sectioned in order to demonstrate that the wall thicknesses are representative of the design under consideration.

## **7.9 Drop Test**

For the purpose of this test, one fully equipped cylinder with padded cover fitted, which is guaranteed by the manufacturer to be representative of the design and which include all marking (in accordance with clause 10) shall be filled with a non-corrosive liquid equivalent to the maximum mass of propane at the maximum filling ratio.

The cylinder shall be dropped vertically onto a flat concrete or steel surface from a height of 1.2 m. The cylinder shall be angled at 30° to the vertical. The valves and fittings shall be uppermost.

Following the test the cylinder shall be subjected to a burst test as specified in **7.2**.

## **7.10 Valve Protection Drop Test**

For the purpose of this test, one fully equipped cylinder with padded cover fitted, which is guaranteed by the manufacturer to be representative of the design and which include all marking (in accordance with clause 10) shall be filled with a non-corrosive liquid equivalent to the maximum mass of propane at the maximum filling ratio.

The cylinder shall be dropped vertically onto a flat concrete or steel surface. The cylinder shall be angled at 30° to the vertical. The valves and fittings shall be nearest the ground. The cylinder shall be rotated so that the shroud impinges on the ground at the weakest point.

Following the test the cylinder shall be subjected to a pressure test as specified in **7.3**. For the purpose of this test, the pressure relief valve shall be removed and the port plugged for testing.

## **8 Acceptance procedure**

### **8.1 General**

**8.1.1** All acceptance testing as required by this clause shall be carried out on finished production cylinders, prior to surface treatment.

**8.1.2** All cylinders shall be subject to a pressure test as specified in 7.3 and examination of the surface of the welds as specified in 7.7.

**8.1.3** Radiographic examination shall be carried out as specified in 7.4.

**8.1.4** Mechanical testing as specified in 7.1 and burst testing as specified in 7.2 shall be carried out on samples as specified in 8.2.

### **8.2 Batch testing**

#### **8.2.1 *Batch***

A batch shall consist of finished cylinders made consecutively by the same manufacturer using the same manufacturing technique, to the same design, size and material specifications on the same type of automatic welding machines. A batch shall consist of not more than 250 cylinders.

NOTE In this context "consecutively" need not imply continuous production.

#### **8.2.2 *Rate of sampling***

Where a batch contains material from more than one cast, the manufacturer shall arrange for samples tested to represent each cast of material used.

**8.2.2.1** From the first batch of cylinders, representative cylinders shall be taken at random, one for the burst test and one for mechanical tests.

**8.2.2.2** From each subsequent batch of cylinders, one representative cylinder shall be taken at random for either a burst test or mechanical tests.

### **8.3 Failure to meet batch test requirements**

**8.3.1** In the event of failure to meet batch test requirements, retesting shall be carried out as specified in 8.3.2.

**8.3.2** If there is evidence of a fault in carrying out the mechanical tests, or of an error of measurement, a second test on the same cylinder shall be performed. If the result of this test is satisfactory, the first test shall be ignored.

**8.3.3** If the test has been carried out satisfactorily, the procedure specified in 8.3.3.1 or 8.3.3.2 shall be followed.

**8.3.3.1** In the event of a single cylinder failing the initial mechanical or burst test, retest of both mechanical and burst shall be made as shown in Table 3, the retest cylinders being taken at random from the same batch.

Table 3 - Batch retest requirements

Failure	Retest
1M	2M + 1B
1B	2B + 1M
NOTE "M" denotes mechanical test and "B" denotes burst test.	

**8.3.3.2** In the event of more than one cylinder failing the initial tests or one or more cylinders failing the retest specified in 8.3.3.1, the batch shall be rejected.

## 9 Technical requirements for type approval

**9.1** The manufacturer shall make available a batch of at least 16 cylinders of each type, from which the competent body shall select cylinders for test as follows:

- a) a fatigue test as specified in **7.8**: 3 cylinders;
- b) mechanical tests as specified in **7.1**: 2 cylinders;
- c) a burst test as specified in **7.2**: 2 cylinders.
- d) a drop test as specified in **7.9**: 1 cylinder.
- e) a drop test as specified in **7.10**: 1 cylinder.

From these cylinders, two shall have radiographic tests as specified **7.4.3**, **7.4.4** and **7.4.5**.

**9.2** A cylinder shall be considered to be of a new design compared with an existing design when:

- it is manufactured in a different factory; or
  - it is manufactured by a different welding or manufacturing process or a radical change in an existing process, e.g. change in cold working operation; or
  - it is manufactured from a steel of different specified chemical composition range;
- or
- the guaranteed minimum yield stress ( $R_o$ ) and/or the guaranteed minimum tensile strength ( $R_g$ ) has changed; or
  - the nominal outside diameter has changed; or
  - the guaranteed minimum wall thickness (a) or the guaranteed minimum end thickness (b) has been decreased

**9.3** Different designs of cylinder shall be considered to be of the type within the following limitations:

a) cylinders of the same diameter and thickness, equipped with the same openings manufactured using the same manufacturing techniques and material specifications and on the same type of mechanised or automatic welding machines except they can differ in length within the following limits:

- the length of the cylindrical shell is not less than three times the outside diameter;
- the length of the cylindrical shell is not more than 1,5 times the length of the cylindrical shell of the cylinders tested.

**9.4** The manufacturer shall apply for, obtain and retain a Design Type Approval Certificate for each different design of cylinder in accordance with the requirements of ADR.

## **10 Marking**

Each cylinder shall be permanently and legibly marked on a nameplate or other appropriate permanently attached non-pressure part, with the marks as prescribed in ADR with the additional statement - FOR USE IN HOT AIR BALLOONS ONLY. The additional marking shall be at least to the minimum size required by ADR.

Where the marking is on the ends of cylinders it shall be demonstrated in the fatigue and burst test that failure does not initiate in the markings and the markings are legible.

## **11. Certificate**

Each batch of cylinders shall be covered by a certificate to the effect that the cylinders meet the requirements of this technical code in all respects.

The certificate shall include;

- a) reference to the design code CYL-HAB-01.
- b) the type approval certificate number.
- c) the batch and serial numbers of the cylinders included in the certificate.
- d) a statement that the cylinders have been proof pressure tested in accordance with clause **7.3**.

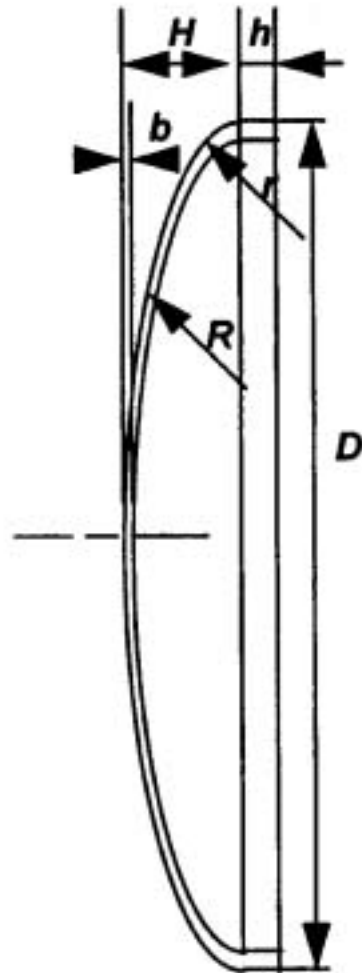

NOTE  $H = R + b - \sqrt{[R + b - (D/2)] \times [(R + b) + D/2 - 2(r + b)]}$

Figure 1 Design of torispherical ends concave to pressure.

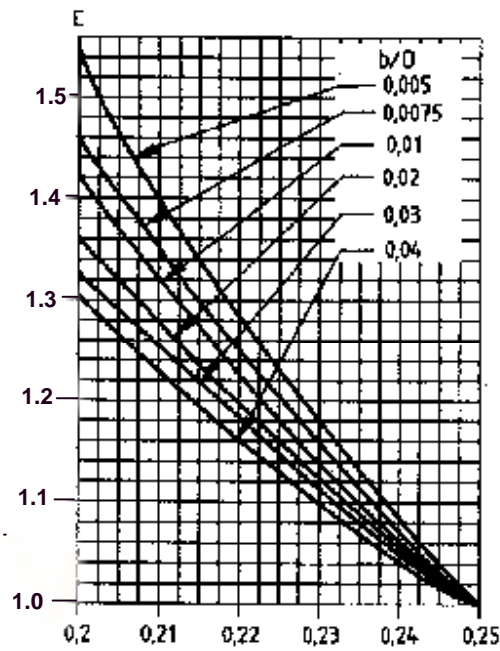

Figure 2 — Values of shape factor  $C$  for  $H/D$  between 0,2 and 0,25

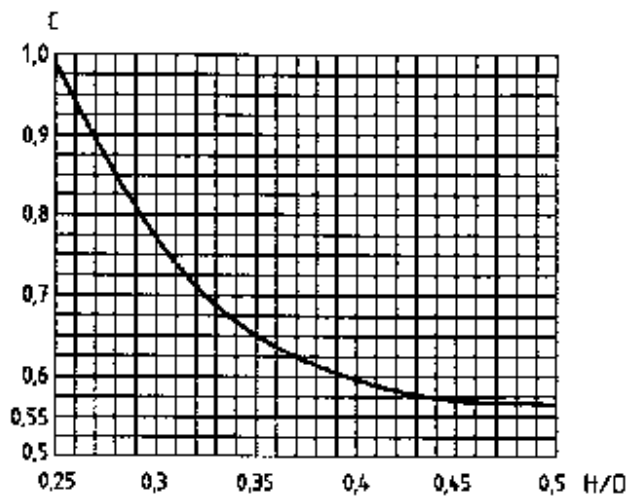
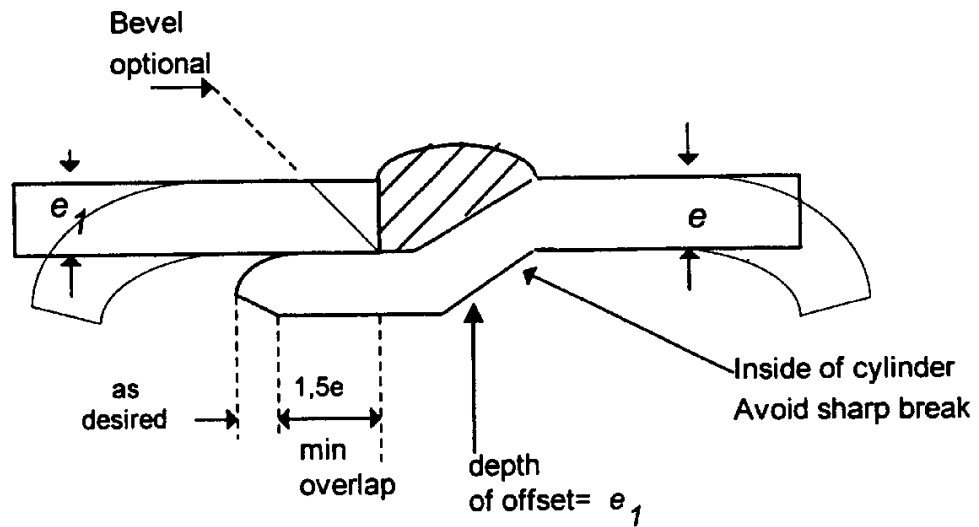
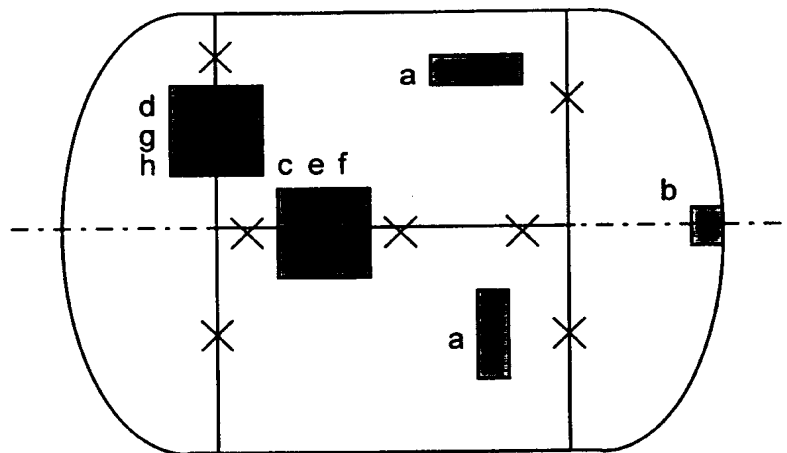

Figure 3 — Values of shape factor  $C$  for  $H/D$  between 0,25 and 0,5



$e$  = thickness of metal which is offset  
 $e_1$  = thickness of metal which is not offset

Figure 4 Illustration of typical joggled butt weld



**a** = alternative locations of test specimen for tensile test  
**b** = test specimen for tensile test  
**c** = test specimen for tensile test  
**d** = test specimen for tensile test  
**e** = test specimen for bend test (topside of the weld)  
**f** = test specimen for bend test (underside of the weld)  
**g** = test specimen for bend test (underside of the weld)  
**h** = test specimen for bend test (underside of the weld)

Figure 5 Locations of test specimens

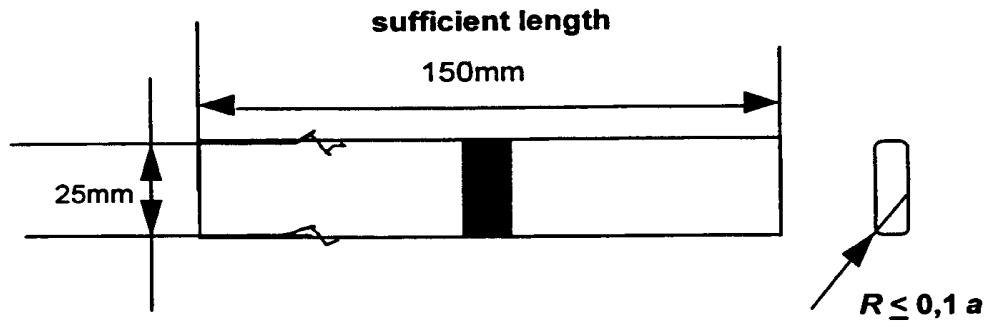

a) Dimension of test specimen

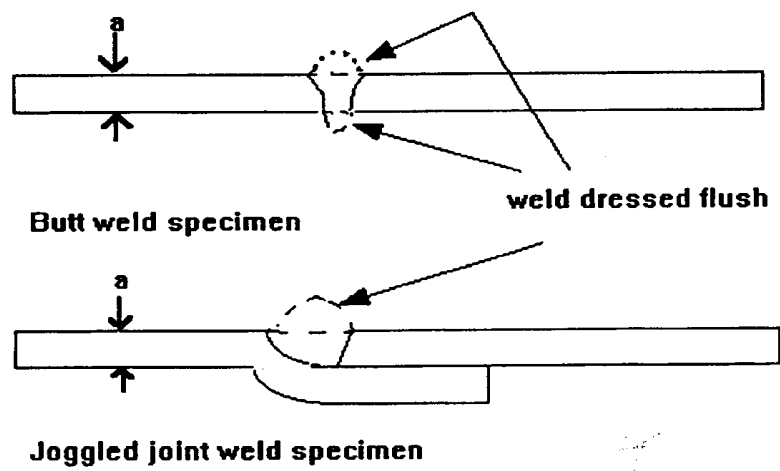

b) Transverse guided bend test specimen preparation

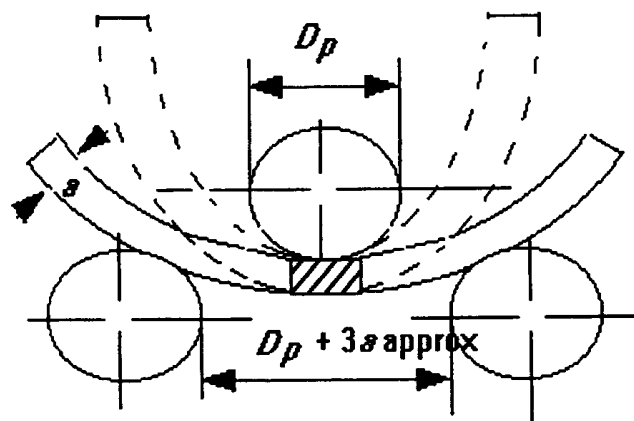

c) Illustration of bend test

Figure 6 Illustration of Bend Test

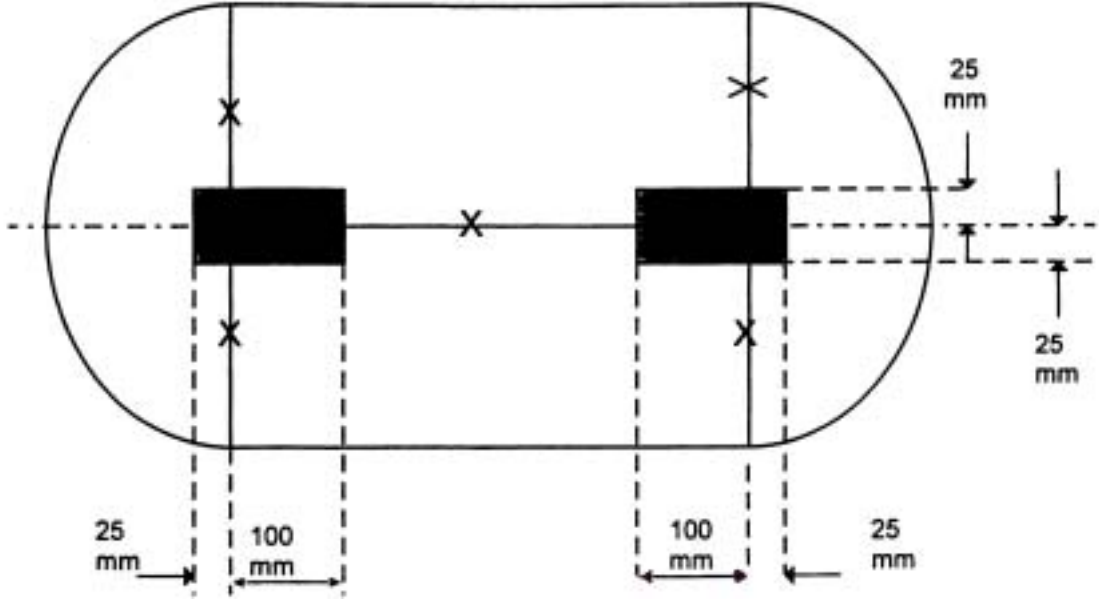
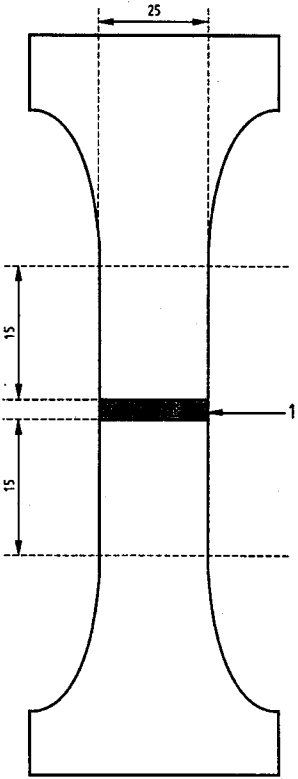

Figure 7 Extent of Radiography of Welds



Key  
1 Weld

Figure 8 Dimensions of test piece