

WD11

Surface planer

COSHH essentials for woodworkers



The Control of Substances Hazardous to Health Regulations 2002 (COSHH) require employers to ensure that exposure is prevented or, where this is not reasonably practicable, adequately controlled. This guidance gives practical advice on how this can be achieved by applying the principles of good practice for the control of exposure to substances hazardous to health, as required by COSHH.

It is aimed at people whose responsibilities include the management of substances hazardous to health at work (eg occupational health specialists, anyone undertaking COSHH assessments, supervisors and is also useful for trade union and employee safety representatives). It will help you carry out COSHH assessments, review existing assessments, deliver training and supervise activities involving substances hazardous to health.

This guidance is issued by the Health and Safety Executive. Following the guidance is not compulsory, unless specifically stated, and you are free to take other action. But if you do follow the guidance you will normally be doing enough to comply with the law. Health and safety inspectors seek to secure compliance with the law and may refer to this guidance.

See Essential information near the end of the sheet.

Control approach: Engineering and RPE

What this sheet covers

This sheet describes good control practice when using a surface planer.

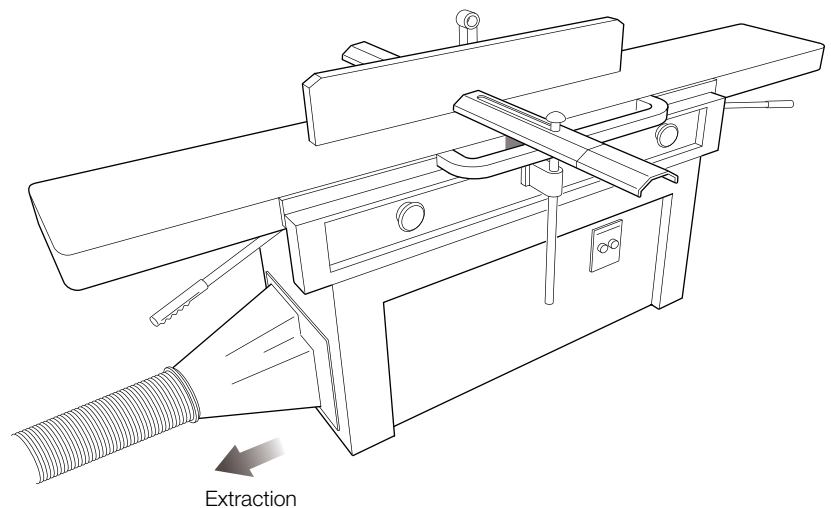

It covers the key points you need to follow to reduce exposure to wood dust to an adequate level. Follow all the points, or use equally effective measures.

It doesn't cover other health and safety risks. Further information on these can be found at the HSE Woodworking web pages: www.hse.gov.uk/woodworking/.

Hazards

- ✓ Surface planing can produce moderate dust levels.
- ✓ Wood dust includes dust from hardwood, softwood and composite boards such as medium-density fibreboard (MDF).
- ✓ Typically, planing hardwoods and MDF can produce dust levels significantly higher than for softwoods.
- ✓ Wood dust can cause dermatitis and serious lung diseases including asthma and cancer.
- ✓ The dermatitis risk is high for softwoods.
- ✓ The workplace exposure limit (WEL) for hardwood and softwood dust is 5 mg/m³ (based on an 8-hour time-weighted average). Due to the health risks associated with wood dust, exposure should be reduced as far below the WEL as reasonably practicable.

Access to work area

- ✓ Allow access to authorised and appropriately trained people only.

Equipment and procedures

- ✓ Fit dust extraction, also known as local exhaust ventilation (LEV), to the machine. Surface planers have a guard over the cutting tool, but typically no top hood. LEV should be fitted below the working surface of the machine. Enclose and extract the cutter beneath the bench to capture dust emitted.
- ✓ To maximise efficiency of LEV, minimise the use of flexible ducting; use rigid ducting wherever possible.
- ✓ Airflow must be sufficient to control contaminants effectively. This will depend on the design, size of opening and the type of process and substance being controlled. Your woodworking machinery manufacturer may be able to provide or recommend volume flow rates (VFRs) for extraction systems fitted to their machines. If this information is not available, VFR data published by ACGIH (see Further information) is an acceptable alternative to which you can refer.
- ✓ Provide adequate clean make up air into the workplace to replace extracted air.
- ✓ Keep the extraction system simple and robust in design (see WIS 23 for further details).
- ✓ Ensure connections between flexible ducts and moveable hoods are secure.
- ✓ Provide an easy way of checking the LEV is working, eg airflow indicator or equivalent.

Respiratory protective equipment (RPE)

- ✓ Provide RPE with a UK Standard Assigned Protection Factor (APF) of at least 20.
- ✓ RPE is also needed for maintenance and cleaning.
- ✓ Fit testing is required for RPE with a tight fitting face seal.
- ✓ Workers wearing tight fitting RPE must be clean shaven and trained how to fit it properly and look after it.
- ✓ Tell workers to discard disposable RPE at the end of the shift, or sooner if their RPE becomes blocked with dust.
- ✓ Change the filters on respirators in accordance with manufacturers' recommendations and if:
 - the shelf-life expiry date has passed;
 - they are damaged or visibly contaminated; or
 - they become harder to breathe through.
- ✓ Examine and test non-disposable RPE thoroughly at least once every month and record this.
- ✓ Tell workers to check RPE is working properly before every use and record this.
- ✓ If RPE is required for extended periods, eg longer than 1 hour, use powered respirators or constant flow airline breathing apparatus.
- ✓ Make suitable arrangements for maintenance, storage and replacement of RPE.

Personal protective equipment (PPE)

- ✓ Ask your supplier to advise on suitable PPE.
- ✓ Consult workers to ensure PPE will be suitable for them.
- ✓ Provide coveralls that do not retain dust.

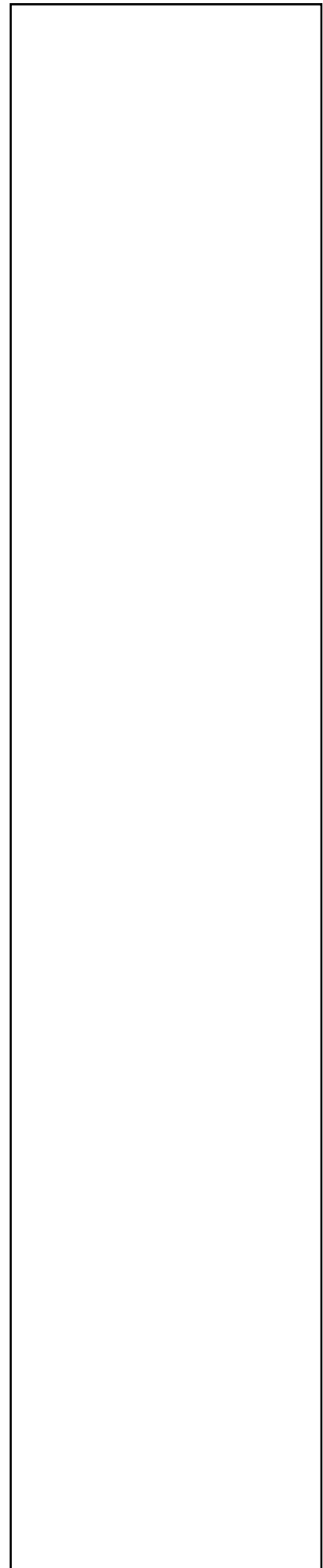

-
- ✓ Use a contract laundry or a suitable equivalent to wash work clothing. Don't allow workers to do this at home.
 - ✓ If required select gloves that are suitable for control of health risks (dermatitis) and safety risks (disintegrate to detach from the hand if they become entangled).
 - ✓ Tell workers to change and discard damaged gloves immediately.
 - ✓ Make suitable arrangements for maintenance, storage and replacement of PPE.

Personal decontamination

- ✓ Provide warm water, mild skin cleansers, and soft paper or fabric towels for drying. Avoid abrasive cleansers.
- ✓ Provide pre-work skin creams, which will make it easier to wash dirt from the skin.
- ✓ Provide after-work creams to replenish skin oils.

Caution: 'Barrier creams' are not 'liquid gloves' and do not provide a full barrier.

Maintenance, examination and testing

- ✓ Keep all equipment used for the task in effective working order. Maintain it as advised by the supplier or installer.
- ✓ Check for signs of damage to control equipment before starting work.
- ✓ Have equipment thoroughly examined and tested against its performance standard, at suitable intervals.
- ✓ For LEV a user manual or log book is helpful in setting out the frequency of checking, maintenance or parts replacement.
- ✓ For LEV with no user manual or log book, you may need the help of a competent person. They can determine the performance needed for adequate control.
- ✓ LEV systems require a statutory 'thorough examination and test' (TExT).
- ✓ Get a competent person to perform the TExT at least once every 14 months.
- ✓ Carry out all actions arising from the TExT.
- ✓ Keep an employer record for at least 5 years of TExT information, eg target extraction rates which show the LEV is performing as originally intended.
- ✓ Several measures are available to check effectiveness of controls. These range from simple qualitative (use of dust lamp) to complex quantitative techniques (eg air sampling) – usually for higher risk scenarios.
- ✓ HSG258 provides more detailed information on LEV systems and legal and competence requirements.

Cleaning and housekeeping

- ✓ Clean work equipment and the work area daily. Clean other equipment and the workroom regularly – at least once a week.
- ✓ Use vacuum equipment that meets at least the dust Class M (medium hazard) classification to remove dust.
- ✓ Alternatively use an appropriate vacuum attachment for your LEV system (see WD17) which is a cost effective solution.

Caution: Never allow the use of brushes or compressed air for removing dust from skin and clothing. Avoid the use of brushes or compressed air for removing dust from surfaces or from inside machinery.

Health surveillance

- ✓ Provide health surveillance for asthma where there is a reasonable likelihood that asthma may occur in your workplace. See G402.
- ✓ Provide health surveillance for dermatitis where there is a reasonable likelihood that dermatitis may occur in your workplace. See G403.

Training and supervision

- ✓ Provide supervision – ensure that safe work procedures are followed.
- ✓ Tell workers about the hazards associated with their work and how to recognise early signs of asthma and dermatitis.
- ✓ Provide workers with training on:
 - working safely with hazardous substances;
 - when and how to use controls;
 - how to check they are working;
 - how the LEV system works;
 - how to use the LEV to get the best out of it;
 - how to check that the LEV is working; and
 - what to do if something goes wrong.
- ✓ Consider keeping training records.
- ✓ Have a procedure to check that control measures are in place and being followed.
- ✓ Involve managers and supervisors in health and safety training.

Essential information

You can find the full COSHH essentials series at www.hse.gov.uk/coshh/essentials/index.htm

Health surveillance, monitoring and sampling sheets are available at www.hse.gov.uk/pubns/guidance/gseries.htm

Health surveillance for occupational asthma COSHH Guidance Sheet G402
HSE Books 2011 www.hse.gov.uk/pubns/guidance/g402.pdf

Health surveillance for occupational dermatitis COSHH Guidance Sheet G403
HSE Books 2011 www.hse.gov.uk/pubns/guidance/g403.pdf

New and existing engineering control systems COSHH Guidance Sheet G406
HSE Books 2011 www.hse.gov.uk/pubns/guidance/g406.pdf

Exposure measurement: Air sampling COSHH Guidance Sheet G409
HSE Books 2011 www.hse.gov.uk/pubns/guidance/g409.pdf

UK Standard Assigned Protection Factor 20 (APF 20) COSHH Guidance Sheet R3
HSE 2016 www.hse.gov.uk/pubns/guidance/rpe3.pdf

Further Information

Occupational Safety and Health Consultants Register www.oshcr.org/

Preventing contact dermatitis and urticaria at work Leaflet INDG233(rev2)
HSE 2015 www.hse.gov.uk/pubns/indg233.htm

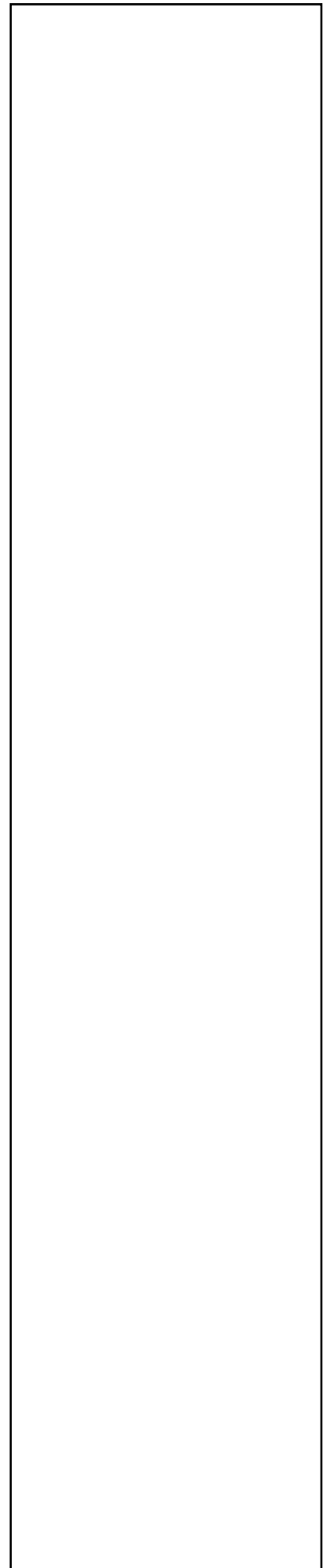

Clearing the air: A simple guide to buying and using local exhaust ventilation (LEV) Leaflet INDG 408 HSE 2008 www.hse.gov.uk/pubns/indg408.htm

Supervising for safety in woodworking Are you as good as you think you are? Leaflet INDG 440 HSE 2010 www.hse.gov.uk/pubns/indg440.htm

Respiratory protective equipment at work: A practical guide HSG53 (Fourth edition) HSE Books 2013 www.hse.gov.uk/pubns/books/HSG53.htm

Controlling airborne contaminants at work: A guide to local exhaust ventilation (LEV) HSG258 HSE Books 2011 www.hse.gov.uk/pubns/books/hsg258.htm

HSE's LEV web page: www.hse.gov.uk/lev/

HSE's RPE web page:
www.hse.gov.uk/respiratory-protective-equipment/index.htm

HSE's woodworking webpage:
www.hse.gov.uk/woodworking/wooddust.htm

Selection of respiratory protective equipment suitable for use with wood dust Woodworking Information Sheet WIS14 HSE 2014 www.hse.gov.uk/woodworking/wis.htm

Wood dust: Controlling the risk Woodworking Information Sheet WIS23 HSE 2012 www.hse.gov.uk/woodworking/wis.htm

Toxic woods Woodworking Information Sheet WIS30 HSE2012 www.hse.gov.uk/woodworking/wis.htm

Industrial ventilation: A manual of recommended practice for design ACGIH 2015 www.acgih.org

For information about health and safety, or to report inconsistencies or inaccuracies in this guidance, visit www.hse.gov.uk/. You can view HSE guidance online and order priced publications from the website. HSE priced publications are also available from bookshops.

Employee checklist

- Do you understand the health hazards associated with your work?
- Is the extraction switched on and working properly, with the baffle plate fully open? Check the airflow indicator has the correct reading.
- Check that any RPE works properly every time you use it.
- Check for signs of leaks, wear and damage in RPE and LEV before every job.
- If you find any problems, tell your supervisor. Don't just carry on working.
- Co-operate with health surveillance.
- Use, maintain and store your PPE in accordance with instructions.
- Wash hands before eating, drinking, smoking, using the lavatory and after work.
- Use skin creams provided as instructed.
- Be aware of early signs or symptoms of ill health related to wood dust and report them as soon as possible.

© Crown copyright If you wish to reuse this information visit www.hse.gov.uk/copyright.htm for details. First published 02/17