

FL5

COSHH essentials for production and use of flour



The Control of Substances Hazardous to Health Regulations 2002 (COSHH) require employers to ensure that exposure is prevented or, where this is not reasonably practicable, adequately controlled. This guidance gives practical advice on how this can be achieved by applying the principles of good practice for the control of exposure to substances hazardous to health, as required by COSHH.

It is aimed at people whose responsibilities include the management of substances hazardous to health at work (eg occupational health specialists, anyone undertaking COSHH assessments, supervisors and is also useful for trade union and employee safety representatives). It will help you carry out COSHH assessments, review existing assessments, deliver training and supervise activities involving substances hazardous to health.

This guidance is issued by the Health and Safety Executive. Following the guidance is not compulsory, unless specifically stated, and you are free to take other action. But if you do follow the guidance you will normally be doing enough to comply with the law. Health and safety inspectors seek to secure compliance with the law and may refer to this guidance.

See Essential information near the end of the sheet.

Flour bagging

Control approach 2 Engineering control

What this sheet covers

This sheet describes good control practice when bagging flour.

It covers the key points you need to follow to help reduce exposure to an adequate level. Follow all the points, or use equally effective measures.

Main points

- Bagging can produce high dust levels.
- Keep exposure as low as possible using all the controls in this sheet.
- Make sure the controls work.
- See sheet FL0.

Hazards

- ✓ Flour dust, enzyme improvers and other ingredient dusts such as egg powder and soya can cause asthma. Even short-term exposures can cause harm.
- ✓ Control exposure to stop occupational asthma developing.
- ✓ When all controls are applied properly, less than 2 mg/m³ flour dust is usually achievable (based on an 8-hour time-weighted average).
- ✓ Frequent hand-washing using soap and detergent can cause dermatitis.

Access to work area

- ✓ Allow access to authorised and appropriately trained people only.

Equipment and procedures

- ✓ Apply local exhaust ventilation (LEV) at the source of exposure to capture the airborne contaminant and enclose the process as much as possible. See illustration.
- ✓ Use a filling nozzle that conducts the displaced air into the extraction.
- ✓ Make sure that the filling nozzle does not spill flour when the bag is removed.

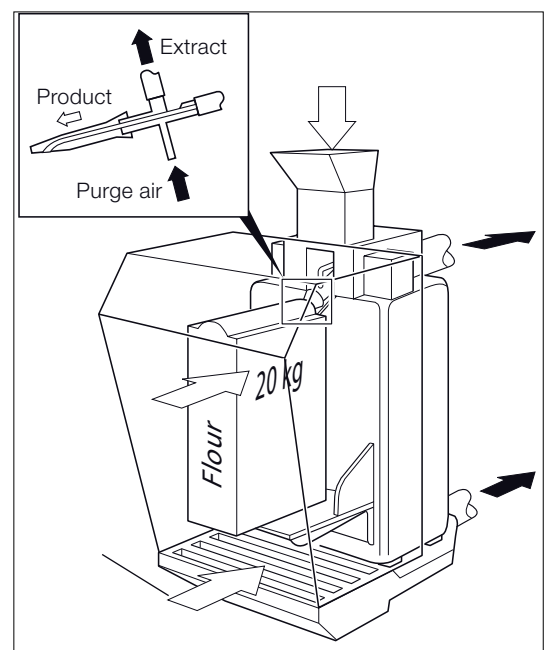

-
- ✓ Provide an extracted hopper at floor level to catch spills.
 - ✓ Airflow must be sufficient to control airborne contaminants effectively. This will depend on the design, size of opening and the type of process and substance being controlled.
 - ✓ Keep extraction ducts short and simple – avoid long sections of flexible duct.
 - ✓ Provide an easy way of checking the LEV is working, eg airflow indicator or equivalent.
 - ✓ Fit an indicator or alarm to show if filters have blocked or failed.
 - ✓ Provide a good standard of general ventilation. This can be natural ventilation from doors, windows etc or controlled, where air is supplied or removed by a powered fan.
 - ✓ Always confirm that the extraction is turned on and working at the start of work. Check the gauge.

Respiratory protective equipment (RPE)

- ✓ RPE is normally not needed.
- ✓ RPE may be needed for maintenance and cleaning.

Personal protective equipment (PPE)

- ✓ Ask your supplier to advise on suitable PPE.
- ✓ Provide coveralls that do not retain dust.
- ✓ Use a contract laundry or a suitable equivalent to wash work clothing. Don't allow workers to do this at home.

Personal decontamination

- ✓ Provide warm water, mild skin cleansers, and soft paper or fabric towels for drying. Avoid abrasive cleansers.
- ✓ Provide pre-work skin creams, which will make it easier to wash dirt from the skin.
- ✓ Provide after-work creams to replenish skin oils.

Caution: 'Barrier creams' are not 'liquid gloves' and do not provide a full barrier.

Maintenance, examination and testing

- ✓ Keep all equipment used for the task in effective working order. Maintain it as advised by the supplier or installer.
- ✓ Check for signs of damage to control equipment before starting work.
- ✓ Have equipment thoroughly examined and tested against its performance standard, at suitable intervals.
- ✓ For LEV a user manual or log book is helpful in setting out the frequency of checking, maintenance or parts replacement.
- ✓ For LEV with no user manual or log book, you may need the help of a competent person. They can determine the performance needed for adequate control.
- ✓ Keep records of all examinations for at least 5 years.
- ✓ LEV systems require a statutory 'thorough examination and test' (TExT).
- ✓ Get a competent person to perform the TExT at least every 14 months.
- ✓ Carry out all actions arising from the TExT.
- ✓ HSG258 provides more detailed information on LEV systems and legal and competence requirements.

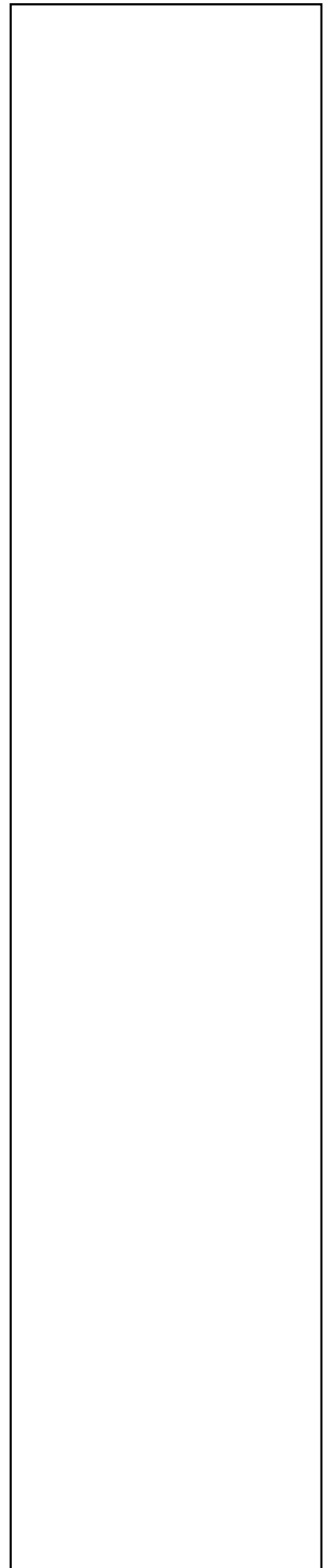

-
- ✓ Several measures are available to check effectiveness of controls ranging from simple qualitative (use of dust lamp) to complex quantitative techniques (eg air sampling) usually for higher risk scenarios.

Cleaning and housekeeping

- ✓ Deal with spills immediately. Provide PPE. Shovel large spills carefully into a waste bag or spill hopper.
- ✓ Clean work equipment and the work area daily. Clean other equipment and the workroom regularly – at least once a week. Include overhead beams, heating pipes and light fittings.
- ✓ Vacuum dry dust or use wet cleaning methods.
- ✓ Use vacuum equipment that meets at least dust Class M (medium hazard) classification to remove dust.
- ✓ Alternatively use an appropriate vacuum attachment for your LEV system which is a cost effective solution.

Caution: Never allow the use of brushes or compressed air for removing dust from skin and clothing. Avoid the use of brushes for removing dust from surfaces or from inside machinery.

Health surveillance

- ✓ Provide health surveillance for asthma where there is a reasonable likelihood that asthma may occur in your workplace. See G402.
- ✓ Provide health surveillance for dermatitis where there is a reasonable likelihood that dermatitis may occur in your workplace. See G403.

Training and supervision

- ✓ Provide supervision – ensure that safe work procedures are followed.
- ✓ Tell workers about the hazards associated with their work and how to recognise early signs of asthma and dermatitis.
- ✓ Provide workers with training on:
 - working safely with hazardous substances;
 - when and how to use controls;
 - how to check they are working;
 - how the LEV system works;
 - how to use the LEV to get the best out of it;
 - how to check that the LEV is working;
 - what to do if something goes wrong.
- ✓ Training records are helpful to demonstrate training has taken place.
- ✓ Changes to the work process and LEV means that staff may need retraining.
- ✓ Involve managers and supervisors in health and safety training.

Essential information

You can find the full COSHH essentials series at www.hse.gov.uk/coshh/essentials/

Health surveillance, monitoring and sampling sheets are available at www.hse.gov.uk/pubns/guidance/gseries.htm

Production and use of flour: Advice for managers COSHH Guidance Sheet FLO HSE 2015 www.hse.gov.uk/pubns/guidance/fl0.pdf

Stand-alone dust collector COSHH Guidance Sheet FL8 HSE 2015
www.hse.gov.uk/pubns/guidance/fl8.pdf

General storage of solids and liquids COSHH Guidance Sheet G101 HSE 2015
www.hse.gov.uk/pubns/guidance/g101.pdf

General advice on chemicals causing harm via skin or eye contact COSHH Guidance Sheet S100 HSE 2015
www.hse.gov.uk/pubns/guidance/s100.pdf

Selection of personal protective equipment COSHH Guidance Sheet S101 HSE 2015
www.hse.gov.uk/pubns/guidance/s101.pdf

Health surveillance for occupational asthma COSHH Guidance Sheet G402 HSE 2011
www.hse.gov.uk/pubns/guidance/g402.pdf

Health surveillance for occupational dermatitis COSHH Guidance Sheet G403 HSE 2011
www.hse.gov.uk/pubns/guidance/g403.pdf

Further information

Local exhaust ventilation (LEV) workplace fume and dust extraction web page: www.hse.gov.uk/lev

Controlling airborne contaminants at work: A guide to local exhaust ventilation (LEV) HSG258 HSE Books 2011
www.hse.gov.uk/pubns/books/hsg258.htm

Occupational Safety and Health Consultants Register www.oshcr.org/

Dust guidance Training package The Federation of Bakers 2008
www.bakersfederation.org.uk

Breathe Easy DVD training package The Federation of Bakers 1998 (includes guidance on dust control and health surveillance in bakeries)
www.bakersfederation.org.uk

For information about health and safety, or to report inconsistencies or inaccuracies in this guidance, visit www.hse.gov.uk/. You can view HSE guidance online and order priced publications from the website. HSE priced publications are also available from bookshops.

Employee checklist

- Keep unprotected people away while you are using flour.
- Is the extraction working? Is there any obvious dust on work surfaces and ledges?
- Work carefully – don't create dust.
- Clean up leaks and spills immediately.
- If you find any problems, tell your supervisor. Don't just carry on working.
- Co-operate with health surveillance.
- If you develop any symptoms that may be related to work, inform your line manager.
- Use, maintain and store your PPE in accordance with instructions.
- Wash hands before eating, drinking, smoking, using the lavatory and after work.

© Crown copyright If you wish to reuse this information visit www.hse.gov.uk/copyright.htm for details. First published 09/16