



Control of noise at power presses

Engineering Sheet No 29

Introduction

This Information Sheet is to help managers to understand how noise exposure may be reduced in press shops. It should be read in conjunction with Engineering Information Sheet EIS26¹ which gives more background information.

Most press users are likely to need specialist advice before attempting to implement noise reduction measures in press shops. This advice may be available from press suppliers, trade associations or noise consultants.²

The problem

Power presses are inherently noisy, and numbers of them are often used in a press shop at the same time, all contributing to a cumulative noise exposure for operators and for nearby workers. Noise levels as high as 95-115 dB(A) are typical in many press shops.

The potential for hearing loss is well known. Some press users have taken some steps to reduce noise at source, but many have not taken all reasonably practicable measures and still rely too heavily on the use of hearing protection by employees.

A control strategy

The Noise at Work Regulations³ require noise assessments to be made if noise levels exceed a daily personal noise exposure ($L_{EP,d}$) of 85dB(A), and noise reduction measures to be taken where these are reasonably practicable. The use of ear protectors is a last resort where control at source is not reasonably practicable, or may be a temporary measure to be used until controls can be implemented.

The key to understanding whether there is a problem is the noise assessment - see EIS 26.¹ The assessment should be more than a series of noise measurements. It should give clear recommendations on what needs to be done to comply fully with the Noise at Work Regulations. In particular, it should either give clear recommendations on what measures can be taken to control noise, including control at source, or should indicate where such help is available. Where noise comes from a range of sources, as will normally be the case in press shops, the assessment should suggest priorities.

On the basis of the assessment, managers should produce an implementation plan to tackle the problems identified. It may be reasonably practicable to make some

improvements quickly, ie in a few weeks; others may take longer. What is important is that there is a realistic and effective plan to deal with the known problems; that the plan is followed, and that where necessary suitable hearing protection is provided and used in the meantime. It will rarely be possible to control noise completely by means of a single control measure. Just as total noise exposure is often the cumulative effect of many noise sources, satisfactory noise reduction may depend on the cumulative effects of a number of separate control measures. Do not under-estimate the effect of an apparently small noise reduction. It is often not appreciated that the decibel scale is logarithmic and that a reduction of 'only' 3dB(A) halves the noise energy.

It may not be reasonably practicable to reduce noise in many press shops to levels where hearing protection is no longer required, but all noise reduction measures will help to reduce the overall risk of hearing damage.

New presses

The Noise at Work Regulations³ require suppliers to provide noise test data for power presses unless a particular machine is unlikely to cause noise exposures of 85dB(A) or more.

The Supply of Machinery (Safety) Regulations⁴ require noise emission data to be provided where the equivalent continuous A-weighted sound pressure level at workstations exceeds 70dB(A). They also require that machinery be so designed and constructed that risks resulting from emission of airborne noise are reduced to the lowest level, taking account of technical progress and the available means of reducing noise, in particular at source.

Users considering buying new presses are advised to ensure that adequate data and noise reduction measures are included with any new power presses offered for sale. Care is needed in interpreting noise emission data because standard test conditions may be very different from actual conditions of use, which themselves may be very variable. Further information on noise reduction at new power presses can be found in BS EN 692:1997.⁵

Control measures

The information which follows is not a design guide but is intended to give press shop managers an outline of the main noise reduction measures they may need to consider. Not all of these measures will necessarily be appropriate at every press or in every press shop.

Information has been included on case studies and sources of further information.^{6,7}

The sources of power press noise identified by a good assessment are likely to be either pneumatic or mechanical:

- pneumatic: compressed air is used in many presses, either for the control system, or for ejecting parts from the tools or both;
- mechanical: from the press action itself, ie tool/workpiece interaction; clutch/gear/flywheel mechanisms; and from workpiece impacts with discharge chutes, collection bins etc.

Technical measures

Various technical measures may be taken to reduce noise from these sources.

Pneumatic exhausts

Pneumatic exhausts should either be ducted away from work positions or fitted with silencers. Care needs to be taken to ensure that excessive back pressures do not adversely affect operating cycle times or control systems, particularly those operating press guards.

Workpiece air ejection nozzles

Noise from ejection air jets can be reduced by any of the following measures or by a combination of them:

- change a continuous jet to an intermittent supply;
- fit acoustic quiet nozzles;
- reduce the duration of the jet;
- reduce the air pressure.

These measures should also result in savings of compressed air.

Case studies

- A combination of the first two measures above, in one instance, reduced noise levels from 99 to 93dB(A) (Ref 6, page 45).
- In another example noise levels were reduced from 97 to 90dB(A) by reducing air pressure from 80 to 20psi (Ref 6, page 28).

Machine design

A good noise assessment will have identified which parts of each press are generating noise. Discussion with press suppliers may reveal modifications which can be made.

Case study

In one instance involving a multi-stage transfer press, redesigning a cam system and replacing straight spur gears on the main drive train with helical toothed gears produced a noise reduction of about 10dB(A) and improved the output of the press (Ref 7, page 70).

Transmission of noise

The flywheels of power presses radiate noise due to vibrations caused both by the operation of the clutch and by the impact of the tooling. Analysis of the vibration patterns and modes of vibration can allow dynamic absorbers to be designed to bond to the flywheel.

Case study

One case study reports an overall noise reduction of 10dB(A) (Ref 7, page 55).

A sheet of metal with felt padding bolted to the outside surface of a flywheel, like a finger touching a bell to damp down its ringing, may have a similar effect and an acoustic cover around the flywheel and gear wheel can further reduce noise from this source.

The transmission of mechanical vibration from a press frame through its supporting legs may result in noise radiating from the legs and floor. Suitable anti-vibration mounts fitted between the press base and the floor may reduce this problem.

Case study

In one published example, a noise reduction of 9dB(A) was achieved by this method, along with the application of self-adhesive damping sheet to the sheet metal surfaces of the press guards which were also radiating noise (Ref 7, page 61).

Tool design

It has been found that including a shear or skew cut in blanking tools (a technique adopted for extending the work range of a power press) can also reduce noise.

Case study

In one example, stamping 16-inch diameter blanks from 2mm thick aluminium sheet using tools modified in this way produced an 8-10dB(A) noise reduction (Ref 6, page 18).

Press enclosure

The provision of acoustic enclosures on hand-fed and automatic, strip-fed presses will significantly reduce noise emission levels in many instances. Partial acoustic enclosures closely fitted around the tools or an existing guard modified to act as a partial acoustic enclosure may also offer significant noise reduction. In other circumstances it may be appropriate to provide an acoustic enclosure around a complete press or whole press line.

An existing guard could be modified to act as a partial acoustic enclosure by covering the guard panels with a lead sheet sandwiched between acoustically absorbent foam, inserting polycarbonate windows where necessary. Such acoustic panels are quite easy to fix using plastic band fixing strips, making sure that all gaps are sealed. Low voltage lighting could be fitted inside the guard to increase visibility.

Case studies

- In one example, enclosing four lines, each of three presses, with acoustic enclosures having full-length access doors, visual inspection panels, internal lighting and integral ventilation reduced noise levels from 95-108dB(A) to 70-80dB(A) at various operating positions, (Ref 6, page 73).
- In another, acoustic treatment of existing guard enclosures on multi-stage, high-speed transfer presses produced noise reductions of up to 11dB(A) per press (Ref 7, page 60).
- In a third example, noise levels from 30-ton power presses blanking from continuous strip were reduced from 105 to 84dB(A) by a combination of measures which included close-fitting acoustic enclosures around the tools (Ref 6, page 28).

Enclosures made by suspending strips of appropriate flexible PVC have been used around individual presses to reduce noise.

Case studies

- Noise reductions of 10dB(A) in two cases and 12-16dB(A) in a third have been achieved in specific examples (Ref 6, page 75; Ref 7, page 59; and Ref 6, page 74 respectively).

Absorption panels

In many press shops, most of the noise to which operators are exposed radiates directly from the nearest presses, but reflected noise from walls and ceilings can contribute to total noise and may sometimes be particularly significant. Sound absorbing panels suspended from ceilings, fitted as wall linings or provided as mobile screens may reduce noise exposures. Depending on the area to be treated, the expense of this type of control measure means that careful thought has to be given to its suitability (ie cost versus benefit) and correct installation.

Case study

In one example, 1400 absorbers suspended from a press shop ceiling produced an overall noise reduction of 4dB(A). (Ref 7, page 58). In another case, similar treatment gave 5-6dB(A) reduction (Ref 6, page 52).

Discharge chutes and collection bins

Press components are often discharged automatically or dropped manually into metal bins, often via metal chutes. Metal to metal impacts often contribute significantly to noise exposures. Bins and chutes can be lined with suitable resilient material like rubber, pvc etc of appropriate hardness; the under or outsides can be coated with sound-deadening compound. Alternatively, acoustic enclosures can be provided around bins.

Case study

Examples from other machine tools in Ref 6, page 36 and Ref 7, page 71 gave noise reductions of 5-10 and about 15dB(A) respectively, and the principles described would be adaptable to many press shop applications.

Press maintenance

Virtually all machinery can be expected to work better, and often more quietly, if it is properly maintained.

Case study

A study of a particular 20-ton press piercing aluminium plate showed that noise reductions at the operator position of between 7 and 16dB(A) were achieved (depending on plate thickness and tool conditions) after the press was refurbished with new bearing shells, properly adjusted slide bearings and oil flood lubrication. The refurbishment also restored the press to its original rated tonnage from the 60% it had been achieving (Ref 6, page 20)

References

- 1 Noise in engineering EIS 26 * and Reducing noise at work: Guidance on the Noise at Work Regulations 1989 L108 HSE Books 1998 ISBN 0 7176 1511 1
- 2 Selecting a health and safety consultant INDG 133 *
- 3 Introducing the Noise at Work Regulations INDG75 * (single copies free; ISBN 0 7176 0961 for priced pack of 15 copies)
- 4 Supplying new machinery INDG270 1998 *; and Product standards: machinery. Guidance notes on UK regulations DTI May 1995 (available free of charge by calling the DTI Hotline 0117 944 4888)
- 5 Mechanical presses - safety BS EN 692: 1997
- 6 100 practical applications of noise reduction methods HSE Books 1983 ISBN 0 11 883691 9 (out of print; photocopies of the case studies quoted are available from HSE's Engineering National Interest Group [Tel 0121 607 6317])
- 7 Sound solutions: techniques to reduce noise at work HSG138 HSE Books 1995 ISBN 0 7176 0791 7

* HSE free leaflet

Further information

The future availability and accuracy of the publications listed in this leaflet cannot be guaranteed.

HSE priced and free publications are available by mail order from: HSE Books, PO Box 1999, Sudbury, Suffolk, CO10 6FS Tel 01787 881165 Fax 01787 313995.

HSE priced publications are also available from good booksellers.

For other enquiries ring HSE's Infoline, Tel: 0541 545500 or write to HSE's Information Centre, Broad Lane, Sheffield S3 7HQ.

HSE home page on the World Wide Web:
<http://www.open.gov.uk/hse/hsehome.htm>

This leaflet contains notes on good practice which are not compulsory but which you may find helpful in considering what you need to do.

This publication may be freely reproduced, except for advertising, endorsement or commercial purposes. The information it contains is current at 6/98. Please acknowledge the source as HSE.

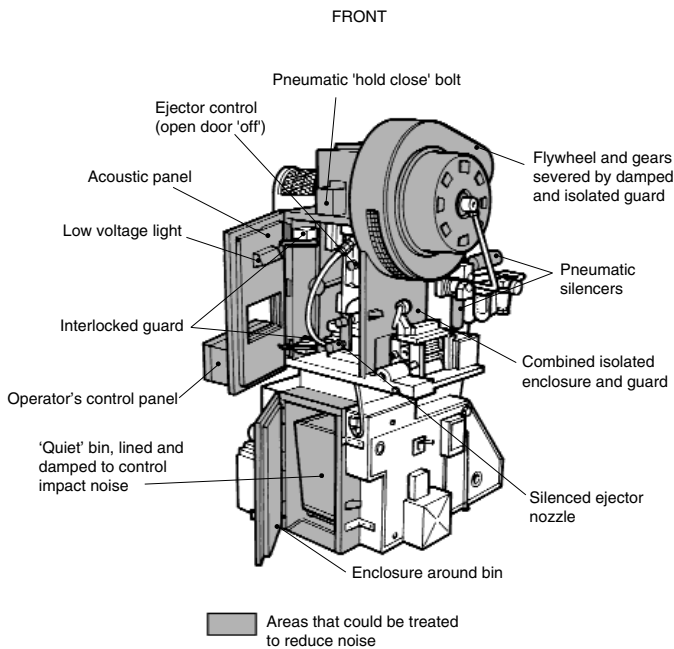

Typical noise sources on a press and some forms of treatment combined with a safety guard

