

# Lifting aids price guide

Manual handling is a major source of back pain. It can often be avoided or the risk reduced by using lifting or handling aids. This sheet, produced in 2006, gives indicative guide prices for the lifting aids described in the HSE leaflet *Are you making the best use of lifting and handling aids?* included in this pack.

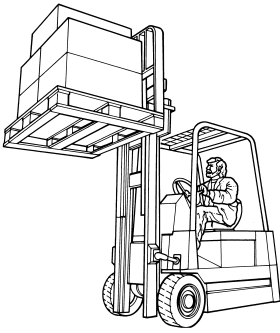

## Bag, sack, box etc, handling

<i>Equipment</i>	<i>Type of risk eliminated/reduced</i>	<i>Price £ (2006)</i>
Fork-lift truck	Eliminates handling and carrying	3000 (used) (50 per week to hire)
Truck with hydraulic lift	Eliminates carrying, and low lifting from truck	795
Ball table and rollers	Reduces carrying distances and improves speed of delivery	30 per 1 m strip
Rotary table	Reduces excessive reaching and lifting from low levels	1950
Vacuum hoist	Eliminates handling and carrying	5000
TV trolley with suction cups	Eliminates handling and carrying the TV	375



## Bales, reels, barrel, drum, keg handling

<i>Equipment</i>	<i>Type of risk eliminated/reduced</i>	<i>Price £ (2006)</i>
Drum/reel rotator	Eliminates handling and carrying large/bulky/heavy containers	3000 (used) (attachment extra) (50 per week to hire)
Keg truck	Eliminates carrying heavy cylinders	130
In-line weighing	Can weigh the items as they are transported	895 (35 per week to hire)
Reel trolley	Eliminates carrying	5000
Reel lifting head	Eliminates carrying and lifting objects that are bulky and unwieldy	1000
Battery powered tug	Eliminates handling and carrying	4100

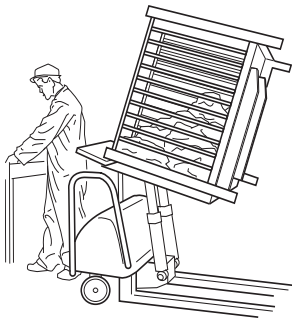

## Packing and unpacking pallets, stillages and containers

<i>Equipment</i>	<i>Type of risk eliminated/reduced</i>	<i>Price £ (2006)</i>
Pallet converter	Eliminates handling	9000
Pallet tilter	Reduces excessive reaching and lifting from low levels	1850
Roller track	Eliminates carrying	Light duty: 135 for 2 m Heavy duty: 385 for 2.4 m
Auto-leveller	Reduces stretching and lifting from low and high heights	2400
Tub hoist	Eliminates handling	110
Bin tilter	Reduces excessive reaching and lifting from low levels	545



## Moving sheet materials

<i>Equipment</i>	<i>Type of risk eliminated/reduced</i>	<i>Price £ (2006)</i>
Fork-lift truck	Eliminates handling	3000 (used) (50 per week to hire)
Pallet truck	Eliminates handling and carrying	200
Gravity rollers	Eliminates carrying	145 per 1.5 m
Sheet trolley/table	Eliminates carrying	285
Vacuum hoist	Eliminates handling and carrying	5000
Lifting hook	Reduces lifting from low heights	40

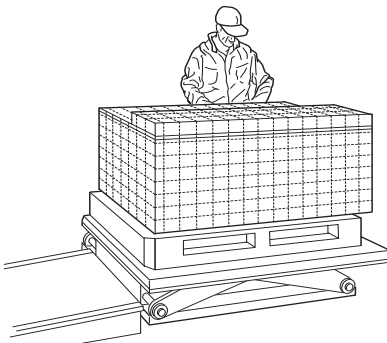

## Storing, warehousing/order picking

<i>Equipment</i>	<i>Type of risk eliminated/reduced</i>	<i>Price £ (2006)</i>
Battery-operated truck	Eliminates handling and carrying	2000
Shelf trolley	Eliminates carrying	35
Conveyor with turntable (flexi-conveyors)	Eliminates carrying	30 per stand
Adjustable height with turntable	Reduces excessive reaching and lifting from low levels	1950
Conveyor and vacuum hoist	Eliminates handling and carrying and avoids carrying distances, lifting unwieldy and/or heavy items	5000
Gravity feed racking	Reduces stretching	390

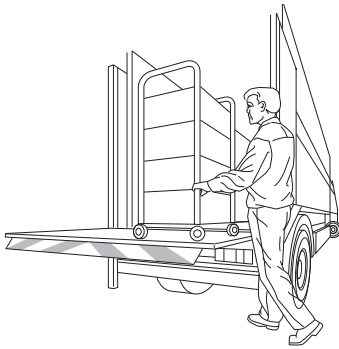

## Goods dispatch/delivery to site/domestic premises

<i>Equipment</i>	<i>Type of risk eliminated/reduced</i>	<i>Price £ (2006)</i>
HGV mounted fork-lift truck	Eliminates handling and carrying	3000 (used) (50 per week to hire)
Star wheeled truck	Reduces handling and carrying	75
Van loading boom	Eliminates carrying	2000-5000 (depending on requirements)
Mobile conveyor	Eliminates carrying	2000 (10 per week per length to hire)
Tail lift	Eliminates carrying	300-600 (60 per week to hire (7.5 t))
Roll cage	Eliminates carrying	110



## Setting and maintenance tasks

<i>Equipment</i>	<i>Type of risk eliminated/reduced</i>	<i>Price £ (2006)</i>
Hoist on vehicle	Eliminates handling and carrying	2000 for hoist only (100 per week to hire)
Wheeled tool box	Eliminates handling and carrying	25
Sliding dies (low-friction surface)	Eliminates handling and carrying	In-house solution
Platform truck	Eliminates carrying and excessive reaching from low levels	225
Valve lifting jig	Eliminates handling	In-house solution
Hand protection	Protects hands from cuts, abrasions etc	10

## Portering, cleaning and waste

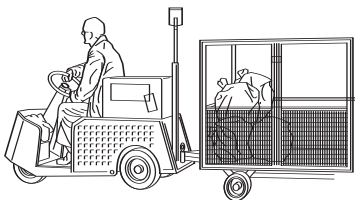

<i>Equipment</i>	<i>Type of risk eliminated/reduced</i>	<i>Price £ (2006)</i>
Powered tug	Eliminates handling and carrying	4100
Cylinder trolley	Eliminates carrying	135
Mobile belt conveyor	Eliminates carrying	2010
Spring-loaded laundry trolley	Reduces excessive reaching and lifting from low levels	550
Mobile crane	Eliminates handling and carrying	845
Mop bucket on wheels	Eliminates handling and carrying	55



## Handling clients\*

<i>Equipment</i>	<i>Type of risk eliminated/reduced</i>	<i>Price £ (2006)</i>
Stair lift	Eliminates carrying	1000 (200 per month)
Stair climbing wheel chair	Reduces handling and carrying	2000
Slide sheet	Reduces handling	30
Adjustable height bed	Reduces excessive reaching and lifting from low/high levels	1150
Stand-aid hoist	Eliminates handling	1800
Hand rails	Eliminates handling and can protect from falling	20

\* Care should be taken in the selection of handling aids which takes into account clients' condition, rights to autonomy, privacy and dignity

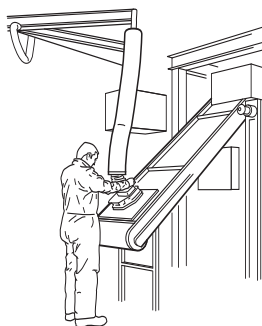

## Construction aids

<i>Equipment</i>	<i>Price £ (2006)</i>
Vacuum hoist	5000 (350-380 per week to hire)
Telehandler	250-300 per week to hire

This document is part of a pack and is not available from HSE Books