



Hand-arm vibration in the cast stone industry: reducing the risk

HSE Information Sheet MISC493

Introduction

This information sheet, produced by the Health and Safety Executive, outlines the risks to workers in the cast stone industry from hand-arm vibration. It is aimed at employers, managers, supervisors, employees and their representatives. The information sheet has been produced to help address the Health and Safety Commission (HSC) priority topic of hand-arm vibration and aims to help the industry by addressing the following questions:

- What is hand-arm vibration syndrome?
- What are the symptoms?
- How can I comply with the law?
- How do I know if there is a risk?
- How do I control the risk?
- What about health surveillance?

What is hand-arm vibration syndrome?

Hand-arm vibration syndrome (HAVS) is a general term embracing various kinds of damage caused by exposing the hands to vibration. The more widely known of these is vibration white finger (VWF), which results from damage to blood vessels. Other forms of damage may be to the nerves and muscles of the fingers and hands, causing numbness and tingling, loss of feeling and reduced grip strength. People who have hand-arm vibration syndrome may also have an increased risk of suffering from carpal tunnel syndrome (CTS). Pain and stiffness in the hands and joints of the wrist, elbows and shoulders are other possible symptoms. HAVS and CTS are reportable diseases under the Reporting of Injuries, Diseases and Dangerous Occurrences Regulations 1995 (RIDDOR).

What are the symptoms?

In the first stages of vibration injury, the worker may notice a tingling sensation or 'pins and needles' in the fingers. This is most noticeable at the end of a working day and may be accompanied by numbness. With continued exposure, the person may suffer periodic attacks in which the fingers turn white when exposed to cold. The extent of this whitening, commonly known as finger blanching, depends on the severity of the condition. Attacks last up to half an hour or longer and often end with painful, throbbing return of blood as the colour of the fingers changes to bright red. In very severe cases, blood circulation may be permanently impaired and fingers may take on a blue-black appearance.

Tingling and numbness may lead to sensory impairment or permanent loss of feeling in the fingertips, making it difficult to undertake delicate jobs. These effects are separate from the tingling that may occur during exposure to vibration. Reduced grip strength can also result.

HAVS usually comes from finger or hand contact with either a powered tool or material being held against a moving surface. The risk of suffering from HAVS depends on:

- the amount of vibration;
- the length of time for which the hands are exposed to the vibration;
- whether tool use is intermittent or continuous;
- workplace temperature;
- individual susceptibility;
- the grip and feed forces applied by the operator;
- the task ergonomics.

In many cases symptoms may take several years to develop. However, they could appear after only a few months in susceptible people who are regularly exposed to high levels of vibration.

How can I comply with the law?

In terms of the health and safety of their employees, employers need to do the following:

- **Assess the risk.** The Management of Health and Safety at Work Regulations 1999 place duties on employers to carry out an assessment of any risks to the health and safety of employees arising from work activities.
- **Eliminate or reduce the risk.** The Health and Safety at Work etc Act 1974 makes it the duty of employers to ensure, so far as is reasonably practicable, the health, safety and welfare of all employees while at work. This includes the duty to ensure risks are adequately controlled.
- **Provide the right equipment.** The Provision and Use of Work Equipment Regulations 1998 require employers to select and provide work equipment that is suitable, with regard to the health and safety risks (including vibration) posed by the use of that equipment.

Everyone is required to ensure that the equipment used in their business conforms to the essential health and safety requirements (EHSRs) - in the case of vibration, the risks should be reduced to a minimum.

Under the Supply of Machinery (Safety) Regulations 1992 (as amended 1994) there is a duty on manufacturers and suppliers of power tools to design, manufacture and supply tools for which risks from vibration have been reduced to the lowest level subject to state of the art.

How do I know if there is a risk?

Operators of tools used in the cast stone industry are known to be at risk when methods of controlling the vibration exposure have not been implemented.

To assess daily vibration exposure, the 8-hour energy equivalent acceleration A(8) is determined. HSE recommend a daily vibration exposure action level of 2.8 m/s² A(8). Above this there is an increased risk of HAVS occurring and HSE expects programmes of preventative measures and health surveillance to be adopted.* Cases of HAVS have been found in the cast stone industry at exposure levels below 2.8 m/s² A(8). The action level should therefore not be regarded as a 'safe' level. In a survey, it was found that 90% of companies surveyed had individuals at a medium or high risk of HAVS. The survey also found that there are many cases of HAVS in the cast stone industry.

Where vibrating tools are used a risk assessment should be carried out. The basis of a risk assessment for HAVS is to determine the daily exposure A(8) of an operator and compare this to the HSE action level of 2.8 m/s² A(8). To determine the A(8) an estimate of the vibration magnitude (m/s²) and the typical duration of use is required. It is sometimes possible to assess the risks by measuring the vibration exposures or calculating them from vibration data provided by tool manufacturers. However, it is often difficult to get reliable and accurate measurements for a specific application of the tool and it is often better to develop preventative programmes based on what is known about the hazard created by the types of tool used. Table 1 shows typical daily exposure levels for tool types used in the cast stone industry.

Table 1 Typical vibration exposure for powered hand-held tools used in the cast stone industry

Tool type	Typical vibration magnitude (m/s ²)	Vibration exposure A(8) (m/s ²)				
		Duration of use (minutes)				
		5	10	20	40	80
Medium pneumatic sand-rammer	35	3.6	5.1	7.1	10.1	14.3
Small pneumatic sand-rammer	20	2.0	2.9	4.1	5.8	8.2
Electric demolition hammer	12	1.2	1.7	2.4	3.5	4.9
Chipping hammer	10	1.0	1.4	2.0	2.9	4.1

The shadings in Table 1 suggest the level of vibration risk from the tool types at a range of daily usage periods. The darker the shading, the higher the risk. Table 2 can be used as an indicator of the symptoms likely to occur for each level of risk and the control measures that should be adopted to reduce the risk to as low as reasonably practical.

How do I control the risk?

Where the risk of employees suffering HAVS is identified you should reduce the risk of injury to as low as reasonably practicable. To do this a programme of preventative measures and the implementation of health surveillance are required. The hierarchy of control is used to aid the development of a programme of preventative measures. Each measure listed in the hierarchy should be examined in turn, and if reasonably practical, applied before the next measure is considered. Not all the control measures may be applicable or practical in your situation. In some cases, you may need to apply more than one control measure to achieve an acceptable reduction in vibration exposure.

Elimination

There may be a number of alternative manufacturing processes that would eliminate the need to use hand-held machinery, such as using a wet mix or self-compacting concrete or automating the process. Elimination of the risk processes should take account of technological advances. This can be achieved by regularly reviewing technological advances with respect to the manufacturing process and eliminating risk processes where reasonably practicable. The validity of alternative production processes should be evaluated and their associated health and safety risks assessed.

* In 2005 the Physical Agents (Vibration) Directive will place legal requirements on employers to reduce vibration exposure to below a limit value (LV) of 5.0 m/s². In addition, the Directive states an action value (AV) of 2.5 m/s².

Table 2 Assessing the vibration risk from your tools

Risk level	Criteria	Symptoms	Action
Low-risk	Exposure likely to be less than 1.4 m/s ² A(8)	Symptoms may appear in people most susceptible to vibration injury	Reassess if job changes or new cases of HAVS are identified
Medium-risk	Exposure likely to be between 1.4 and 5.6 m/s ² A(8)	Symptoms likely in people most susceptible to vibration injury after a few years' exposure	Implement risk control actions. Set priorities in detailed risk assessment
High-risk	Exposure more than 5.6 m/s ² A(8)	Symptoms likely in many people after a few years' exposure to vibration	Urgent need for control of risk

The medium-risk zone includes exposure below HSE's recommended action level but HSE's recommendation for programmes of preventative measures and health surveillance should be assumed to apply.

Substitution

Your range of products may require a number of processes to be adopted. Work that involves higher-vibration exposure should only be undertaken when lower-vibration alternatives are not reasonably practicable. Where it is necessary to use hand-held tools, the tool capable of performing the required task with the lowest exposure to vibration should be used. The adoption of any alternative manufacturing technique should be carried out in conjunction with a full assessment of all the risks from both the original and proposed new operations so that the overall benefit can be determined.

The types of equipment commonly used in the cast stone industry are:

- **Automated machinery:** Fully or partly automated machinery can be used for the manufacture of standard blocks and products of simple design. This process dispenses with the need for hand-held machinery but manual handling assistance is required.
- **Quoin press:** These manual presses may have vibrating tables to aid compression. They are used when large volume production of a single design is required. Although the vibration from manually operated quoin presses is often lower than power tools, there may be risks associated with upper limb disorders.
- **Demolition hammers and chipping hammers:** These tools are fitted with a vibrating plate attached to a tool. They tend to have lower vibration magnitude than sand-rammers but are heavy and require balancing rigs to reduce the manual handling risks.
- **Sand rammers:** These tools have high vibration and require a number of control measures to reduce the risks. However, it may be necessary to use these tools during the manufacture of small or ornate products. Use of these tools should be

avoided where lower-risk processes are applicable.

- **Hand tools:** Hand tools, for example hammers and mallets, are used to perform a hammer-type action and are often used to compress the material around the edges of the moulds. These tools may produce upper limb disorders if they are not ergonomically designed.

Engineering controls

Engineering control can involve either the selection of low-vibration tools and/or the retrospective fitting of vibration-reduction solutions to tools.

Selection of low-vibration tools

Your purchasing policy for tools should include an assessment of the tool's ability to do the job, an evaluation of the vibration and an ergonomic assessment. Vibration data supplied by the manufacturer can be used during the assessment of the risks. However, you need to ensure the manufacturer's test conditions are valid for the intended use of the tool. If it is thought the test conditions are not applicable to the use of the tool, typical in-use vibration data should be requested. It is important to use tools with the correct power to perform the task. Tools that are too powerful for the job will result in the operator being exposed to unnecessarily high vibration. Tools that are not powerful enough may result in operators using the tool for long periods of time and using excessive forces to carry out the task.

Reducing the vibration from tools retrospectively

Vibration-reduction solutions include the reduction of the vibration magnitude from the tool, arranging the tool so the operators can operate the tools safely with reduced grip and using tools designed to avoid the need for workers to grip high-vibration parts.

Example 1 Vibration reduction of demolition hammers

It is possible to reduce the vibration from electric demolition hammers by mounting the tools in a frame attached to a balancing rig to take the weight of the tool and ease tool movement. The tool is mounted in a frame similar to that shown in Figure 1. The tool and frame assembly is then attached to a superstructure via a counterbalance. This allows the tool to be moved across the workpiece with ease, reducing the forces required to do the job.

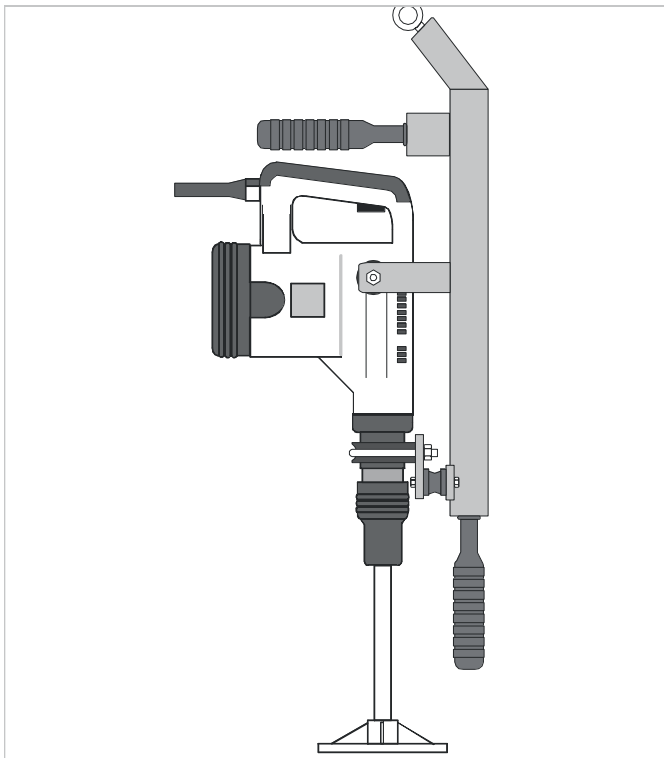

Figure 1 Electric demolition hammer mounted in a frame

This technique has been shown to reduce the vibration from these types of tool from 12 m/s^2 to approximately 6 m/s^2 . This means that the tool mounted in the frame can be used for around 100 minutes before the HSE action level is exceeded, compared to about 25 minutes when the tool is not mounted in the frame. The counterbalance reduces risks associated with the manual handling of the tool. With careful design of the workplace, the risks associated with stretching can also be reduced (eg with the use of rotating bench tops). Training is required to ensure the operators avoid holding the high-vibration parts of the tool (ie the shaft of the tamping foot and the throttle handle of the tool). To achieve this, either a foot-operated throttle or locking throttle is required to avoid contact with the tool during operation.

Example 2 Vibration reduction of sand-rammers

Unless great care is taken during the design of retrofit handles attached to sand-rammers, it is unlikely that any useful reduction in vibration will be achieved. In fact many attempts to fit retrofit handles to sand-rammers **increase** the risks of HAVS. To achieve any reduction in the vibration, the resonant frequency of the retrofit handle system should be, at most, half the fundamental driving frequency of the tool (fundamental driving frequency of sand rammers is typically between 12 and 24 Hz).

It is, however, possible to reduce the vibration from rammers by mounting them in a semi-rigid balancing arm as shown in Figure 2.

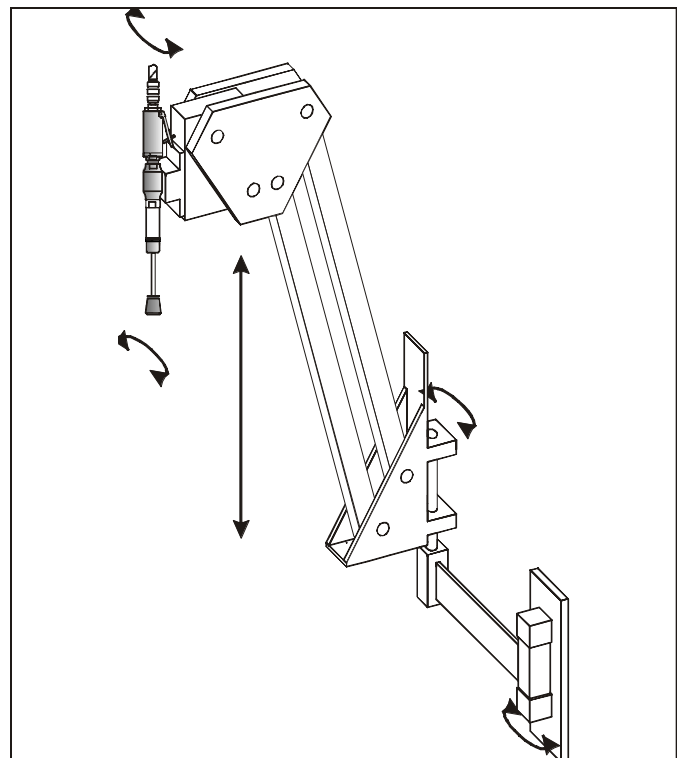

Figure 2 Sand-rammer mounted in a semi-rigid balancing arm

Using this technique, it is possible to reduce the vibration of a small sand-rammer from 20 m/s^2 to 10 m/s^2 . This means that the tool mounted in the frame can be used for about 40 minutes in a working day before the HSE action level is exceeded, compared to about 10 minutes when the tool is not mounted in the frame. In addition, the support offered by the balancing arm means that the operator can guide the tool with the palm of their hand rather than gripping the tool, thereby lowering the risk from the vibration exposure even further.

Management controls

There are a number of management controls available which can help reduce the effects of vibration exposure or limit the exposure itself. These include basics like:

- choosing the correct tool for the job;
- regular monitoring of exposure times and vibration magnitudes;
- correct and routine maintenance of tools;
- training workers in operation techniques which minimise the need to grip tools tightly and avoid contact with high-vibration parts of the tool;
- implementing a system to enable workers to report cases of ill health relating to the use of vibrating equipment;
- managing the work to avoid long periods of uninterrupted vibration;
- implementing job rotation;
- maintaining good temperature control;
- management of piecework to avoid unsafe practices and unnecessary exposure to vibration;
- maintaining up-to-date records of tool use and vibration levels;
- reassessment of processes to reduce risk;
- providing effective personal protective equipment (eg thermal and protective gloves).

The risk to the operator can also be reduced by good operational procedures, correct selection and operation of tools and good ergonomic design of the workstation.

Personal protection

Anti-vibration gloves are unlikely to reduce the dominant, low-frequency energy vibration from tools used in the cast stone industry. However, operators can reduce the risk of HAVS by wearing thermal gloves and warm clothes to keep their hands and bodies warm when using vibrating tools. Training is required to ensure operators are aware of the steps they can take to reduce the risks of HAVS.

The risk of HAVS can be reduced by:

- keeping hands away from the cold exhausts of pneumatic tools;
- warming up before starting work by performing some exercises or manual work;
- alternating tool use with manual work to maintain good blood circulation;
- massaging and exercising fingers during work breaks to help blood circulation;
- allowing tools to do the work and avoiding gripping tools tightly by only applying grip force necessary to operate the tool safely;
- avoiding smoking.

What about health surveillance?

HSE recommends health surveillance for workers who are regularly exposed to above 2.8 m/s² A(8). Health surveillance will not prevent injury in the way that control measures outlined in this information sheet will, but it can be used to detect early signs of injury and prevent significant handicap. Where health surveillance is to be implemented, consultation with the workforce should take place to ensure that they are aware of the reasons behind it.

A health surveillance programme should include:

- training tool operators in methods of reducing the risk including correct tool operation, rest breaks etc;
- a mechanism to enable workers to report any symptoms such as episodes of finger blanching;
- clinical examination and completion of a questionnaire;
- keeping records of when health surveillance was done and the outcomes;
- feedback of the outcomes to employees on an individual basis;
- feedback of the health issues to employers to help them evaluate their risk control programmes.

A pre-employment assessment should be used to identify those individuals who suffer from a variety of medical conditions (eg Raynaud's disease) and establish a baseline from which to judge the results of routine assessments. The pre-employment assessment also provides an opportunity to educate workers about the effects of hand-arm vibration and methods of reducing the risks.

Detailed advice on health surveillance is given in HSE publications *Health surveillance at work* and *Hand-arm vibration* (see 'Further reading').

Further reading

RIDDOR explained: Reporting of Injuries, Diseases and Dangerous Occurrences Regulations Leaflet HSE31(rev1) HSE Books 1999 (single copy free or priced packs of 10 ISBN 0 7176 2441 2)

Health surveillance at work HSG61 (Second edition) HSE Books 1999 ISBN 0 7176 1705 X

Hand-arm vibration HSG88 HSE Books 1994 ISBN 0 7176 0743 7

Management of health and safety at work. Management of Health and Safety at Work Regulations 1999. Approved Code of Practice and guidance L21 (Second edition) HSE Books 2000 ISBN 0 7176 2488 9

Supply of Machinery (Safety) (Amendment) Regulations 1994 SI 1994/2063 The Stationery Office 1994 ISBN 0 11 045063 9

Five steps to risk assessment Leaflet INDG163(rev1) HSE Books 1998 (single copy free or priced packs of 10 ISBN 0 7176 1565 0)

Health risks from hand-arm vibration: Advice for employees and the self-employed Leaflet INDG126(rev1) HSE Books 1998 (single copy free or priced packs of 15 ISBN 0 7176 1554 5)

Health risks from hand-arm vibration: Advice for employers Leaflet INDG175(rev1) HSE Books 1998 (single copy free or priced packs of 10 ISBN 0 7176 1553 7)

Power tools: How to reduce vibration health risks - Guide for employers Leaflet INDG338 HSE Books 2001 (single copy free or priced packs of 15 ISBN 0 7176 2008 5)

Vibration solutions: Practical ways to reduce the risk of hand-arm vibration injury HSG170 HSE Books 1997 ISBN 0 7176 0954 5

The successful management of hand-arm vibration CD-ROM HSE Books 2000 ISBN 0 7176 1713 0

Safe use of work equipment. Provision and Use of Work Equipment Regulations 1998. Approved Code of Practice and guidance L22 (Second edition) HSE Books 1998 ISBN 0 7176 1626 6

Hand-arm vibration in foundries Guidance HSE Books 2001 ISBN 0 7176 1798 X

Further information

The Stationery Office (formerly HMSO) publications are available from The Publications Centre, PO Box 276, London SW8 5DT Tel: 0870 600 5522 Fax: 0870 600 5533 Website: www.tso.co.uk (They are also available from bookshops.)

HSE priced and free publications are available by mail order from HSE Books, PO Box 1999, Sudbury, Suffolk CO10 2WA Tel: 01787 881165 Fax: 01787 313995 Website: www.hsebooks.co.uk (HSE priced publications are also available from bookshops and free leaflets can be downloaded from HSE's website: www.hse.gov.uk.)

For information about health and safety ring HSE's Infoline Tel: 08701 545500 Fax: 02920 859260 e-mail: hseinformationservices@natbrit.com or write to HSE Information Services, Caerphilly Business Park, Caerphilly CF83 3GG.

This leaflet contains notes on good practice which are not compulsory but which you may find helpful in considering what you need to do.

© *Crown copyright* This publication may be freely reproduced, except for advertising, endorsement or commercial purposes. First published 05/03. Please acknowledge the source as HSE.