

Waste industry safety and health

Reducing the risk



Introduction

This leaflet has been produced by the Health and Safety Executive (HSE) in consultation with the Waste Industry Safety and Health Forum (WISH).

It is written for supervisory staff and employees and provides a checklist of standards to aim at.

This leaflet does not interpret health and safety law, nor does it claim to be comprehensive or definitive in its advice and guidance, for example, guidance on waste collection activities has been excluded. However, this leaflet may help duty holders in the industry to devise, institute, monitor and revise methods of work at their sites.

Other more extensive guidance published by HSE, ESA, IWM, WAMITAB, the Composting Association and other bodies can be used to supplement the information in this leaflet.

Transport

Vehicle movements cause deaths and some of the most serious accidents in the waste industry. The aim is to ensure:

- a safe site;
- a safe vehicle;
- a safe way of working;
- a safe worker.

Here is a brief checklist for your site. It doesn't aim to cover everything, but may help you identify areas that need improvement on your site.

Does your site have the following?

Safe site	Yes	No
Effective segregation of people, vehicles and mobile plant to prevent collisions		
Enforced speed limits		
A clear site layout (especially for visiting drivers)		
Adequate means to prevent vehicle contact with overhead power lines		
Roads designed and maintained to cater for vehicles/plant on site (no tight corners, very steep gradients, potholes etc)		
'Blind corners' eliminated at junctions		
Mirrors fitted to any 'blind corners' that remain		
One-way systems where possible to minimise collisions and reversing activities		
Traffic movement controls, eg clear and unambiguous traffic signs, such as 'One-way', 'No entry' etc, and traffic lights, especially at transfer stations and landfill sites		
Safe vehicles		
Vehicles with good all-round visibility, eg mirrors and CCTV camera systems		
Vehicles fitted with seatbelts - are these seatbelts always used?		
Vehicles regularly examined to ensure that all parts are working, especially brakes, lights, steering, vision aids and tyres		
Systems to ensure well-maintained skips and containers (especially their doors), lifting appliances, hooks, chains etc		
Safe working systems		
Discharging restricted to identified/specified areas		
Discharging areas fitted with adequate restraints to prevent vehicles and/or people falling into discharge pits		
Adequate separation from other vehicles and obstructions during tipping: <ul style="list-style-type: none"> ● at least one vehicle width maintained between vehicles ● no obstructions within the arc of tip for tipper lorries 		
Suitable areas and equipment to permit safe sheeting and unsheeting		
Safe access for work under tipper containers, eg props		
Safe workers		
High-visibility clothing worn by all pedestrians on site (including drivers outside their cabs)		
Sufficient training, instruction and supervision for all workers on site to ensure that the site rules are understood and carried out		
Written instructions issued to all on site outlining the site rules - do you want them to sign for receipt and to indicate that they understand them and undertake to abide by them?		
Adequate enforcement procedures for the site rules		

Sheeting and unsheeting of vehicles and containers

Workers have been killed by falling off the vehicle while sheeting. The risks exist both at the drivers' 'home base' and also when they collect and/or drop off. Risks are increased in poor light levels and weather conditions.

Automatic sheeting systems

The best solution is for vehicles to be fitted with automatic sheeting systems. Where reasonably practicable, automatic systems can be retrofitted to existing fleets. They remove or reduce the risks associated with:

- sheeting both on and off site;
- walking on loads where there is a risk of tripping or falling into hidden voids.

Drivers find these systems safer, easier and faster to operate.

Progressive site operators are moving towards auto-sheeting over the next few years by planning to:

- purchase all *new* vehicles with auto-sheeting systems;
- retro-fit existing vehicles in a phased manner;
- renew contracts only with hauliers who have auto-sheeting systems fitted.

'Our auto-sheeter vehicles can make four extra visits a day which allowed us to pay back the fitting costs in about six months. They are now contributing towards healthier profits' Waste management company, Midlands

Working platforms and gantry/harness systems

These systems can reduce the risks associated with sheeting vehicles, but can have disadvantages when compared to auto-sheeting systems:

- They can be comparatively cheap to install, but the running costs of maintenance, training and supervision can be high.
- They cannot reduce the sheeting risks off-site.
- They are difficult to move around a site.
- Regular maintenance and thorough checks for wear and tear are needed.

‘We have had no sheeting accidents since installing our gantry/harness system. It was cheap to install, but the costs of maintenance and supervision make it expensive to operate. Our new contract requires all vehicles visiting the site to have automated sheeting systems’

Transport Manager, South Wales

Walking on loads

Walking on loads to either sheet or trim the load exposes the worker to:

- falls into voids in the load;
- slips, trips and falls;
- wounds and subsequent infection from sharp objects.

To remove the need for walking on the load, whoever fills the container should make sure:

- the container is not overfilled;
- the load is evenly distributed.

Reversing

Each year, deaths are caused by reversing vehicles. Wherever possible, the need for reversing should be eliminated or reduced by good site design and layout.

Vision

For good all-round vision when reversing, closed-circuit television (CCTV), or mirrors, or a mix of both, should be fitted to vehicles; the use of mirrors or CCTV alone may be insufficient. They should be checked at least daily and maintained in good working order.

The reliability and quality of CCTV is now high and the costs of fitting and maintenance are low. At a cost of around £500, CCTV can pay for itself in reducing vehicle and property damage within a few months. All subsequent savings add to the company's profits.

Workman killed by reversing vehicle

Crown Court levies fines of £175 000 plus £38 000 costs on the two companies involved. The court heard from an expert witness that 'camera systems are fairly negligible in terms of cost - they're well within the reach of any transport operator...The commercial excuse has gone. With a camera system you are giving a driver the best possible aid to reversing'. The court also heard that all new refuse collection vehicles were fitted with camera systems and that they were becoming a popular means of ensuring all-round visibility for a greater range of vehicles.

Audible warnings

Don't rely too much on 'reversing alarms'. They may be a useful additional safeguard when risks cannot be adequately controlled by segregating pedestrians from vehicle movements, and eliminating unnecessary reversing. They cannot be heard by everyone, and on a busy, noisy site they can become part of the background noise or cause confusion when more than one vehicle is reversing. The environmental impact of the noise and operating times may have to be considered.

Banksmen

Guiding vehicles by banksmen is a very high-risk activity which should be eliminated where reasonably practicable by improving site layout or providing suitable visibility aids. Where banksmen are essential, then:

- they should be adequately trained;
- they should wear appropriate high-visibility clothing and be visible at all times during vehicle movements;
- employees and visiting drivers must understand and obey their instructions;
- the system must be *enforced* to ensure compliance.

These bird's-eye views of reversing vehicles show the dangers to banksmen and pedestrians.

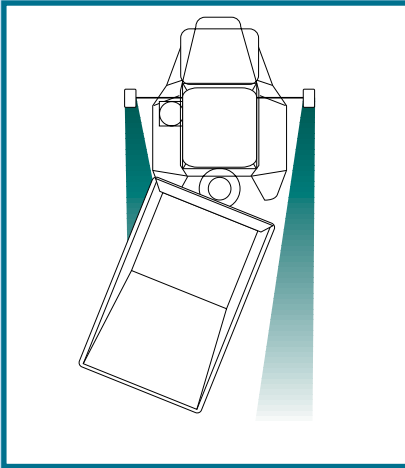

People standing outside the tinted areas can't be seen and could be injured or killed.

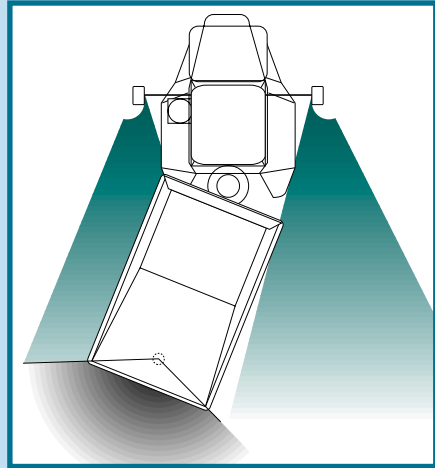

CCTVs and better mirrors improve rearward vision.

Machinery guarding

Are your machines safe to use? Suppliers should provide the right safeguards by law, but in reality, this is not always the case. A new machine should not be assumed to have appropriate safeguards, so it should be thoroughly checked before first being used.

- *Fixed guards*, which effectively prevent anyone touching the dangerous parts, are often the best - it is obvious when they are in place. They should be secured by nuts and bolts etc so they can't easily be removed. Wire mesh, sheet steel or similar materials are good; plastic is easily damaged.
- *Interlocked guards* may be the solution if you regularly need to clear blockages, lubricate, or clean. These guards prevent the machine operating unless the guard is shut, and cannot be opened while the machine is moving. The interlock switches used should be durable and non-defeatable.
- *Photoelectric devices*, pressure-sensitive mats or automatic guards are used where fixed or interlocked guards are impractical.
- *Controls* should be clearly marked to show what they do. 'Start' buttons and pedals should be shrouded to prevent accidental operation: emergency stop controls should be kept in good working condition and should be in easy reach.

Check and maintain

- Fixed guards must be replaced after any removal.
- Use a checklist for daily, weekly or 'before use' checks.

Work safely

- Only authorised people should use a machine.
- Operators need sufficient information, instruction and training in safe use.
- Machinery should not be capable of moving when dangerous parts can be touched.
- Report faulty controls and guards. Your safety may depend on it!

Operators' checklist

Before working	Yes	No
Are you authorised and trained to use the machine?		
Do you know how to stop the machine before you start it?		
Does the emergency stop control work?		
Are all guards in position and safety devices working properly?		
Is your working area clean, tidy and free from obstructions?		
Can you tell your supervisor immediately if the machine and safeguards are not working properly?		
Are you wearing appropriate protective clothing and equipment, eg safety glasses, shoes etc?		
Have you made sure that dangling chains, loose hair, loose clothing etc can't get caught up in the moving machinery?		
NEVER:		
● try to clean a machine while it is in motion;		
● distract people who are using machines.		

Causes of major injuries in the waste industry

Conveyors

Serious injuries occur when guarding has been removed to:

- clear spillages and blockages, and then is not replaced;
- replace belts or adjust the tracking.

Conveyors should never be set in motion without the guards being in place.

Balers and similar machines

Ram shear traps should be suitably guarded. Where traps cannot be guarded, then:

- manual loading and machine working should be a one-man operation and all others should be excluded from the working area;

- controls should be of a 'hold-to-run' design; release should stop ram movement and ideally return it to the safe 'home' position;
- it should not be possible to reach the ram traps from the controls.

Operators should have a good, unobstructed view of the whole operation and immediate vicinity.

Slips and trips

The large numbers of injuries caused by slips and trips are not inevitable. Effective solutions are often simple, cheap and can lead to better, easier working conditions and improved work effectiveness.

Many accidents occur when people are carrying objects and their ability to balance is lessened. Where this work activity takes place, then thought should be given to eliminating the need for carrying. See the section in this leaflet on manual handling for ideas on how to do this.

A special word about outdoor areas

Rain puddles, mud, ice and poor lighting increase the risks in outdoor areas and consideration should be given to:

- eliminating the use of rough ground where this can be reasonably achieved. Some activities may be better moved to suitable concreted areas;
- keeping rough ground as level as possible. In some cases, regular levelling may be needed to remove ramps, areas of subsidence, deep vehicle wheel ruts etc. Pedestrian routes over rough ground should be suitably designated, marked and maintained;

12 *Waste industry safety and health - Reducing the risks*

- improving drainage to remove standing water. Consider the benefits of laying chippings;
- treating footpaths in frosty weather;
- improving lighting.

Major causes of slips and trips

Here is a brief checklist of some of the major causes of slips and trips at waste management sites. It does not aim to cover risks in refuse collection where special and sometimes different risks arise.

Hazard	Possible solutions
Spillage of wet and dry substances and items	<ul style="list-style-type: none"> ● Can you prevent the spillage in the first place? ● Clear away spillages immediately. ● Do you have suitable materials to clear away wet spillages (eg suitable cleaners for greasy liquids, absorbent pellets etc)? ● If spillages of items are inevitable, or where floors may remain wet for some time, such as after cleaning, then can pedestrians be warned and diverted by using barriers and signs?
Waste mounds on floors (eg before loading into compactors or before sorting)	<ul style="list-style-type: none"> ● Can they be restricted to designated areas or contained? ● Can pedestrian routes close to them be re-routed? ● Do employees walk on the mounds? Can the system of work be changed to prevent this?
Trailing cables, hoses etc	<ul style="list-style-type: none"> ● Reposition electrical or water outlets to minimise the need for trailing cables and hoses. ● Position equipment to avoid pedestrian routes. ● Restrict pedestrian access. ● Use suitable covers for pipes and cables.
Office rugs and mats, lino, tiles etc	<ul style="list-style-type: none"> ● Ensure they are securely fixed and have no curling edges. ● Select suitable floor coverings bearing in mind the wear and tear they are expected to take. ● Keep in a good state of repair.
Slippery surfaces	<ul style="list-style-type: none"> ● Minimise pedestrian traffic. ● Can suitable proprietary floor treatments be applied to minimise the slipperiness?
Changes from wet to dry floor surface	<ul style="list-style-type: none"> ● Provide doormats, foot-scrapers etc to prevent water/mud being taken onto dry floors. ● Change footwear if necessary. ● Warn of risks by using signs.
Poor lighting	<ul style="list-style-type: none"> ● Improve lighting levels, replace end-of-life bulbs, keep bulbs clean.
Changes in floor level - slopes and steps	<ul style="list-style-type: none"> ● Improve lighting levels. ● Add high-visibility tread nosings and floor markings. ● Is a handrail appropriate?
Unsuitable footwear	<ul style="list-style-type: none"> ● If the type of work requires it, employers are required by law to provide special protective footwear free of charge. ● Are employees aware of your rules regarding wearing appropriate footwear? What do you do to ensure they wear suitable footwear?

Look after your health

The following precautions can protect your health

Protect your skin – work safely and wear your protective gloves and clothing.

Avoid cuts to the skin. Cuts and grazes can allow ‘bugs’ and chemicals into your body. You could become infected.

Avoid contact with chemicals. Some chemicals may be mixed in the waste, such as aggressive cleaning fluids or oils. These can damage or irritate the skin and cause problems like dermatitis.

Keep your hands away from the nose, eyes and mouth. ‘Bugs’ or chemicals picked up onto the hands can find an easy way into the body through the eyes, nose and mouth.

Always wash your hands

Before eating, drinking or smoking make sure your hands are thoroughly cleaned with soap under running water. Don’t make it easy for ‘bugs’ or chemicals on your hands to get into your mouth.

Don’t breathe in dusts and airborne ‘bugs’

Some jobs can make clouds of airborne ‘bugs’ and dusts which can be breathed into the lungs. ‘Bugs’ can reach deep down inside your lungs where they can cause permanent damage to breathing. To stop this happening:

Avoid causing dust clouds

- Don’t use compressed air for cleaning.
- Use vacuum cleaners or damp sweeping methods for cleaning floors.

Use air extraction systems

- Make sure they are well maintained and kept in the best position to extract the dust.

- Filtering systems fitted to materials handling vehicles can prevent contaminants entering the cab. (Ordinary air-conditioning systems are not effective for this - proper filters need to be fitted.) If filters are fitted, then cab windows and doors should be kept shut so that only filtered air enters the cab.

Wear your face-mask

The last line of defence is wearing a suitable mask to cover your nose and mouth. It should be:

- chosen by someone competent to ensure it gives the right amount of protection;
- well fitting and you should have had proper training in how to use it, when to use it and how to keep it in good condition;
- kept clean and well-maintained.

Disposable masks should only be worn once, then thrown away.

Keep your vaccinations up to date

You should have current vaccinations for:

- tetanus;
- polio.

Some workers may have been vaccinated for hepatitis A, and depending on the type of work done, may have been vaccinated for other possible illnesses.

If you do fall ill

Let your doctor know the work you do - it may help determine the best treatment for you. Landfill workers, in particular, should know of the risks from contact with rats' urine (known as leptospirosis or Weil's disease). For more information see HSE's pocket card *Leptospirosis: Are you at risk?* Pocket card INDG84 HSE Books 1990 (single copy free or priced packs of 20 ISBN 0 7176 2546 X).

Is your health being regularly monitored?

Many employers evaluate staff health to identify any problems at an early stage. This may be a medical examination by an occupational health doctor or nurse, or sometimes a simple questionnaire.

Welfare facilities

A failure to adequately maintain welfare facilities leads to the very real risk of illness, and this is particularly true of the waste industry. Are the following facilities provided at your site?

Welfare provision	Yes	No
Clean, well-ventilated toilets (separate for men and women unless each convenience has its own lockable door)		
Enough wash basins of sufficient size, with hot and cold running water		
Soap and towels (or hand driers)		
Skin cleansers and nail brushes		
Barrier cream and skin-conditioning cream where necessary		
Drying facilities for wet clothes if outdoor work is carried out		
Lockers or hanging space for other clothing		
Changing facilities if special clothing needs to be worn		
A clean drinking water supply (marked if necessary to distinguish it from the non-drinkable supply)		
Rest facilities, including facilities for eating food which would otherwise become contaminated		

Remember that welfare facilities need to be kept clean and consumable materials (soap, toilet paper, towels etc) need to be kept stocked. Somebody will need to be given the responsibility for this.

Manual handling

The waste industry has particular features which make manual handling a major source of injury. To reduce the risks, there are three key duties to address:

- Avoid the need for hazardous manual handling, as far as is reasonably practicable.
- Assess the risk of injury from any hazardous manual handling that can't be avoided.
- Reduce the risk of injury from hazardous manual handling as far as is reasonably practicable.

Avoiding manual handling

- Check whether you need to move it at all.
- Think about mechanisation, such as fork-lift trucks and conveyors.

Assess the task

Can you:

- improve the workplace layout to improve efficiency?
- reduce the amount of twisting and stooping?
- avoid lifting from floor level or above shoulder height?
- reduce carrying distances?
- avoid repetitive handling?
- vary the work so that one set of muscles can rest while another is used?

The load - Can you make it:

- lighter or less bulky?
- easier to grasp?
- more stable?

The workplace - Can you improve it by:

- removing obstructions to free movement?
- providing better flooring?
- avoiding steps and steep ramps?

- preventing extremes of heat and cold?
- improving lighting?

For the staff, can you:

- take better care of those who have physical weaknesses (eg bad backs etc)?
- give them more or better information or training?
- promote less restrictive clothing and personal protective equipment?

If you must handle manually, here is a checklist of the steps to take:

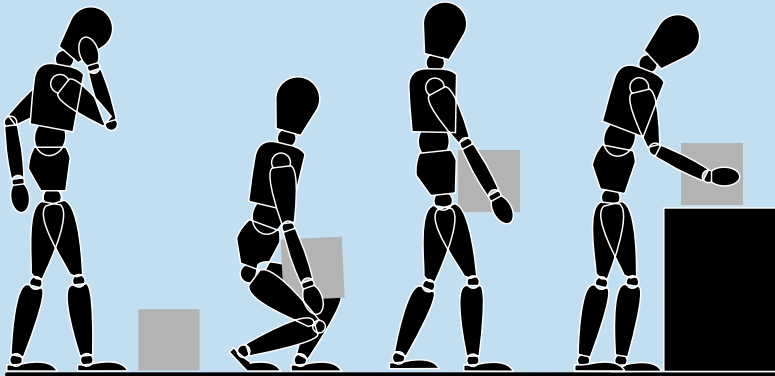

<p>Step 1 Think</p>	<p>Step 2 Get into position, grip and lift</p>	<p>Step 3 Move</p>	<p>Step 4 Lower the load</p>
--------------------------------	---	-------------------------------	---

- | | | | |
|---|---|---|---|
| <ul style="list-style-type: none"> ● Double check. Is there really nothing you can use to help you? No lifting aids at all? No sack truck, hoist, fork-lift truck? ● Plan the lift. Do you need help? Is the area free of obstructions? Can you get the load and destination closer together? | <ul style="list-style-type: none"> ● Place the feet apart, leading leg forward ● Get a firm grip - keep your arms within the boundary formed by the legs ● Make your legs do the work, not your back ● Don't jerk | <ul style="list-style-type: none"> ● Move the feet - don't twist the body ● Keep the load close to the body | <ul style="list-style-type: none"> ● Put the load down ● Then adjust the load |
|---|---|---|---|

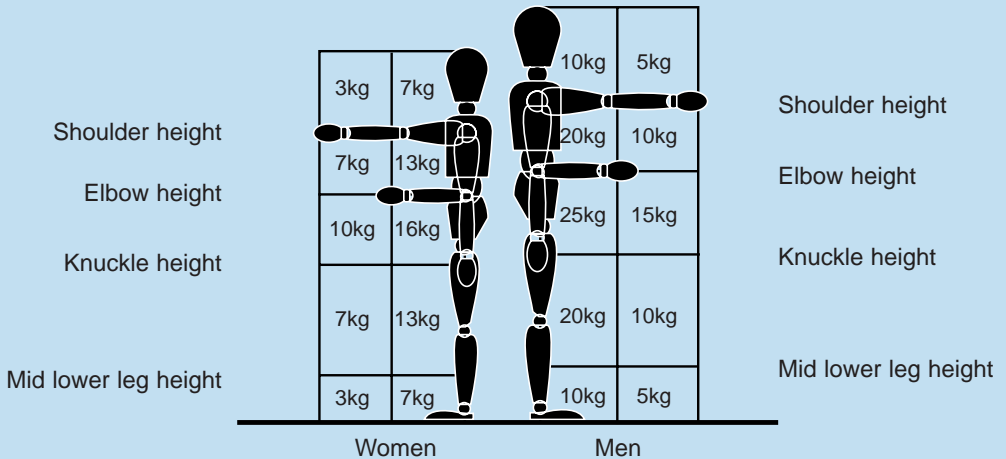

- Each box in the diagram above shows guideline weights for lifting and lowering.
- Observe the activity and compare it to the diagram. If the lifter's hands enter more than one box during the operation, use the smallest weight. Use an in-between weight if the hands are close to a boundary between boxes. If the operation must take place with the hands beyond the boxes, make a more detailed assessment.
- The weights assume that the load is readily grasped with both hands.
- The operation takes place in reasonable working conditions with the lifter in a stable body position.
- Any operation involving more than twice the guideline weights should be rigorously assessed - even for very fit, well-trained individuals working under favourable conditions.
- There is no such thing as a completely 'safe' manual handling operation. But working within the guidelines will cut the risk and reduce the need for a more detailed assessment.

Waste Management Industry Training Advisory Board (WAMITAB): Raising competence - reducing accidents

The number of accidents in the waste industry can be reduced by all those involved having an understanding of the causes of accidents, the legal requirements which exist, safe working practices, and can demonstrate that they are technically competent to carry out the work they are engaged in. The Waste Management Industry Training Advisory Board (WAMITAB) administers schemes which address the issue of competence and health and safety issues.

Since 1996, over 2800 individuals have achieved a statutory vocational qualification. The non-statutory scheme is at an early stage of take-up. As the numbers of successful employees increase, hopefully this will have a positive effect on helping to reduce accidents in the waste management workplace.

The Statutory Competence Scheme

For managerial and supervisory staff at disposal facilities, technical competence has to be demonstrated according to a statutory scheme.

As part of the requirements of the Waste Management Licensing Regulations 1994, those employees that **manage or control** waste landfill, treatment, transfer, incineration and civic amenity sites have to be technically competent. To demonstrate competence, candidates have to achieve an appropriate vocational qualification and then are issued with a Certificate of Technical Competence by WAMITAB and a laminated competence card.

Health and safety benefits from the Statutory Competence Scheme

To achieve the vocational qualification, each individual must have underpinning knowledge relevant to health and safety and be able to demonstrate that he/she can maintain safe and productive working conditions on the site.

The benefits of the vocational qualification are to:

- raise awareness of health and safety issues in the context of the operation;
- make individuals recognise their own roles and responsibilities as far as health and safety are concerned; and
- introduce or refine health and safety policies.

The Non-Statutory Competence Scheme

For employees involved in waste collection and transportation there is a non-statutory scheme. Competence may be demonstrated through the achievement of an appropriate vocational qualification.

With the industry, WAMITAB has developed other vocational qualifications that are available for staff and employees operating throughout the chain of responsibility. These are typically at VQ Levels 1 and 2 and contain two health and safety units:

- Contributing to the maintenance of a healthy and safe working environment.
- Complying with emergency procedures.

WAMITAB issues successful candidates with a Certificate of Competence and a laminated competence card.

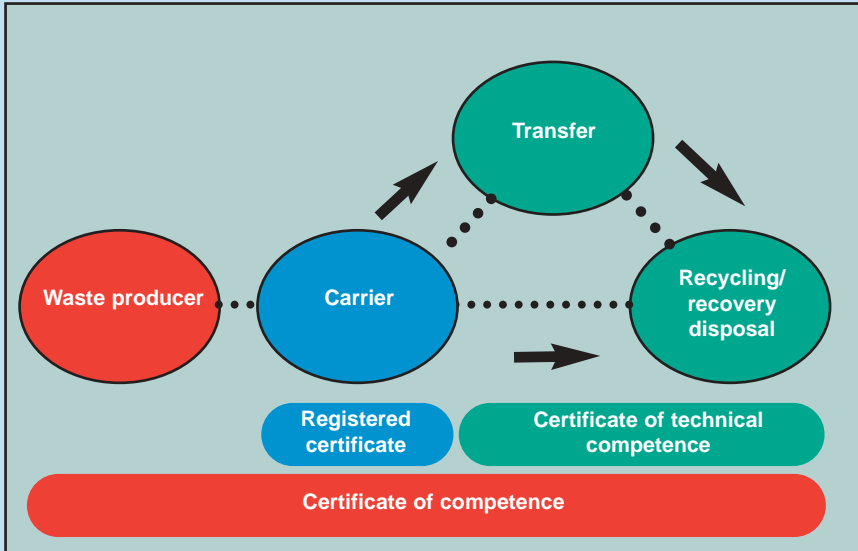

Health and safety benefits from the Non-Statutory Competence Scheme

The Certificate of Competence enables individuals to demonstrate their competence in a practical way and is appropriate for:

- waste producers' staff and employees that have a hands-on responsibility for waste management, often at the critical interface with the contractor;
- drivers and collection employees in the private sector;
- drivers and collection employees in the public sector;
- operatives and other employees at landfill, treatment, transfer and incineration facilities (at levels below manager/supervisor).

Case studies within the public sector have shown that the number of lost time accidents and minor accidents have been reduced with subsequent savings for the employer.

Personal protective equipment

Are you properly dressed? Consider the risks. Employers should provide suitable protective equipment and it is your duty to wear it.

Protect your head

If there is a real risk of items falling on you, you must wear a helmet.

Protect your eyes

Think of the risk of particles from moving machinery and heavy dusts. Would it be sensible to wear protective glasses?

Protect your ears

Noise can damage your hearing permanently. If you can't clearly hear someone speaking two metres away then it is likely you need to wear ear plugs or muffs.

Protect your lungs

You may need to wear a mask (see section on health).

Hands and feet

Skin punctures from sharp items hidden in waste can allow 'bugs' into your body. Hidden chemicals can be absorbed into the skin. Wear appropriate puncture-resistant and/or waterproof gloves where there are these risks.

***More importantly – be seen! Transport accidents kill.
High-visibility clothing may save your life.***

HSE priced and free publications are available by mail order from HSE Books, PO Box 1999, Sudbury, Suffolk CO10 2WA Tel: 01787 881165 Fax: 01787 313995
Website: www.hsebooks.co.uk (HSE priced publications are also available from bookshops and free leaflets can be downloaded from HSE's website: www.hse.gov.uk.)

For information about health and safety ring HSE's Infoline Tel: 08701 545500
Fax: 02920 859260 e-mail: hseinformationservices@natbrit.com or write to
HSE Information Services, Caerphilly Business Park, Caerphilly CF83 3GG.

This leaflet contains notes on good practice which are not compulsory but which you may find helpful in considering what you need to do.

This leaflet is available in priced packs of 5 from HSE Books, ISBN 0 7176 2514 1.
Single free copies are also available from HSE Books.

© *Crown copyright* This publication may be freely reproduced, except for advertising, endorsement or commercial purposes. First published 05/02. Please acknowledge the source as HSE.



*This leaflet is produced by the
Health and Safety Executive (HSE)
with the help of the Waste Industry
Safety and Health forum (WISH).*

*It is written for supervisory staff and
employees and provides a checklist
of standards to aim at.*