

SL3

COSHH essentials for slate works: Silica



This information will help employers (including the self-employed) comply with the Control of Substances Hazardous to Health

Regulations 2002 (COSHH), as amended, to control exposure to respirable crystalline silica (RCS) and protect workers' health.

It is also useful for trade union safety representatives.

This sheet describes good practice using respiratory protective equipment (RPE) and dust extraction.

It covers the points you need to follow to reduce exposure to an adequate level.

It is important to follow all the points, or use equally effective measures.

Main points

- High dust levels result from slate sawing.
- Breathing in dust may cause silicosis.
- Keep exposure as low as possible using all the controls in this sheet. Make sure the controls work.
- You need air sampling. See sheet G409.
- Health surveillance is usually needed. See sheet G404.

Sawing slate into special sizes and shapes

Control approach R RPE

Hazard

- ✓ Cutting, splitting or dressing slate can produce airborne respirable crystalline silica (RCS).
- ✓ All RCS is hazardous, causing silicosis. This is a serious lung disease causing permanent disability and early death.
- ✓ Silicosis is made worse by smoking.
- ✓ 'Respirable' means that the dust can get to the deepest parts of the lung. Such fine dust is invisible under normal lighting.
- ✓ Keep inhalation of RCS as low as possible.
- ✓ When all controls are applied properly, less than 0.1 mg/m³ RCS is usually achievable (based on an 8-hour time-weighted average).

Crystalline silica concentrations in common materials

- ✓ Slate contains up to 40% crystalline silica.

Access and premises

- ✓ Only allow access to authorised staff.
- ✓ Locate the controls away from the machinery.
- ✓ Floors should slope gently towards gulleys, to help dust removal by wet washing.

Equipment

- ✓ Respiratory protective equipment (RPE) is normally needed to reduce exposures to an acceptable level.
- ✓ Sawing creates coarse and fine dust which tends to blow towards the worker. Fit extraction to minimise the escape of dust.
- ✓ Fit dust extraction beneath the machine table, and to the top guard.
- ✓ Can you also use water suppression?
- ✓ You need an inward air speed between 10 and 20 metres per second into the table slot and the top guard.
- ✓ Fit a manometer or pressure gauge near the extraction point, to show that the system is working properly.
- ✓ Mark the acceptable range of readings.
- ✓ With multiple extraction points, a simplified pressure check method may suffice.

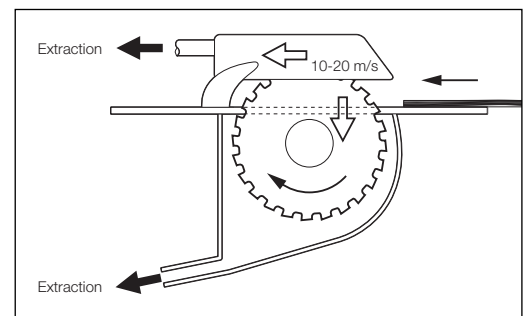

-
- ✓ Discharge cleaned, extracted air to a safe place outside, away from doors, windows and air inlets.
 - ✓ Have a supply of clean air coming into the workroom to replace extracted air.
 - ✓ Fit an indicator or alarm to show if filters have blocked or failed.
 - ✓ Consult a qualified ventilation engineer to design new control systems or to update current controls. See sheet G406.

Procedures

- ✓ Always confirm that the extraction system is turned on and working before starting work.
- ✓ Make sure that workers check that their RPE works properly every time they put it on.
- ✓ Adjust the top guard down as close as possible to the workpiece.
- ✓ Keep the extraction slot and top guard free of slate chips for effective dust capture.
- ✓ Shake down air filters regularly (eg every hour), or use automated reverse-jet cleaning.
- ✓ Make sure you can get spares easily.

Maintenance, examination and testing

- ✓ Minerals and silica-containing dusts are very abrasive. Plan regular maintenance.
- ✓ Follow the instructions in the manual - keep equipment in effective and efficient working order.
- ✓ Check that filter seatings are in good condition.
- ✓ If the dust extraction or filtration plant is faulty, stop work until it is repaired.
- ✓ Maintain all RPE in effective and efficient working order.
- ✓ Keep airline oil and water traps empty, and filters clean.
- ✓ Daily, look for signs of damage. Make repairs.
- ✓ At least once a week, check that the dust extraction system and gauges work properly.
- ✓ You need to keep all controls in good working order. See sheet G406 for advice on engineering controls.
- ✓ You need to know the manufacturer's specifications to check the extraction's performance.
- ✓ If this information isn't available, hire a competent ventilation engineer to determine the performance needed for effective control.
- ✓ The engineer's report must show the target extraction rates.
- ✓ Keep this information in your testing log-book.
- ✓ Get a competent ventilation engineer to examine the extraction thoroughly and test its performance at least once every 14 months. See the HSE publication HSG54 - see 'Further information'.
- ✓ Keep records of all examinations and tests for at least five years.
- ✓ Review records - failure patterns show where preventive maintenance is needed.
- ✓ Check the air flow and air quality to air-fed RPE at least once every three months or before use. Ensure that compressors (including mobile compressors) take in only clean air.

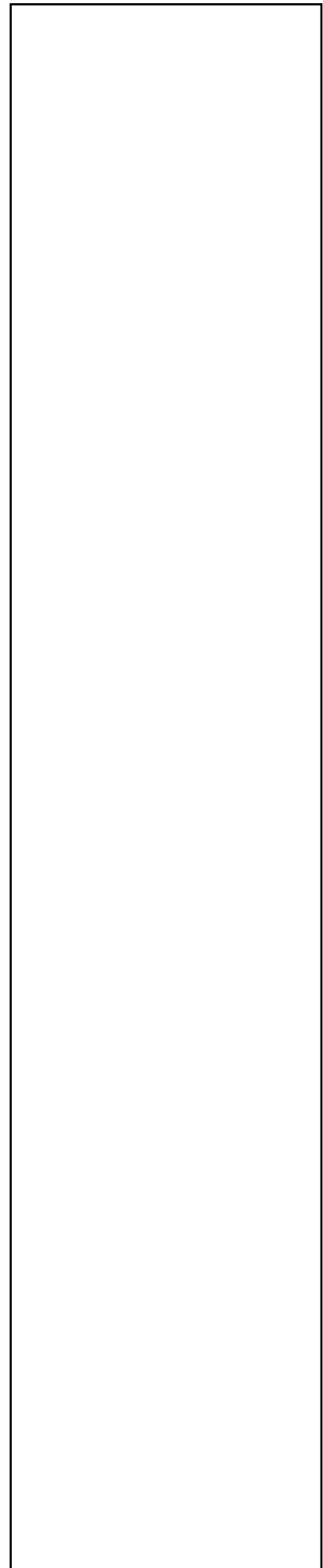

-
- ✓ Make sure that users examine their RPE and test it works properly every time they use it.
 - ✓ Keep records of these tests.
 - ✓ Carry out air sampling to check that the controls are working well. See sheet G409.

Personal protective equipment (PPE)

- ✓ Ask your safety equipment supplier to help you get the right PPE.
- ✓ Provide storage for clean and contaminated PPE.

Respiratory protective equipment (RPE)

- ✓ RPE is needed and must be compatible with hearing protection.
- ✓ RPE is often needed for maintenance and some cleaning jobs.
- ✓ Select RPE that suits the wearer, the job and the work environment. Powered or air-fed RPE is more comfortable to wear.
- ✓ Decide the level of protection from air sampling data. Otherwise, use RPE with a UK standard assigned protection factor (APF) of at least 40. See sheets R4 and R5.
- ✓ Make sure all RPE is properly fit-tested - get advice from your supplier.
- ✓ Train workers to check their RPE works properly before use.
- ✓ Replace RPE filters as recommended by your supplier.
- ✓ Keep RPE clean and store it away from dust.

Other protective equipment

- ✓ Provide clean, dust-resistant coveralls.
- ✓ Use a contract laundry or a suitable equivalent to wash work clothing. Warn them that the dust contains silica.
- ✓ Skin creams help in washing contamination from the skin. After-work creams help to replace skin oils.

Caution: Never allow use of compressed air for removing dust from clothing.

Health surveillance

- ✓ You need health surveillance unless exposure to RCS is well below the limit. See sheet G404.
- ✓ Consult an occupational health professional - see 'Useful links'.
- ✓ Wet work can lead to dermatitis. Check regularly for skin dryness or soreness.

Cleaning and housekeeping

- ✓ Wash down the workroom at the end of each day's work.
- ✓ Use a Type H vacuum cleaner fitted with a HEPA filter, or wet clean.

Caution: Don't clean up with a brush or compressed air.

Training and supervision

- ✓ Tell workers that silica dust can cause serious lung diseases.
- ✓ Working in the right way and using the controls correctly is important for exposure control. Train and supervise workers. See sheet ST0.

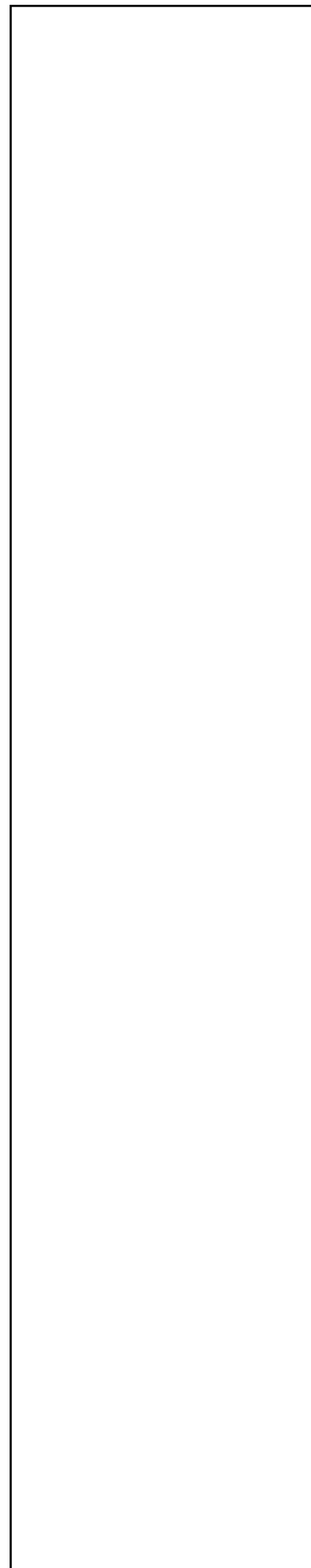

Further information

- *Maintenance, examination and testing of local exhaust ventilation* HSG54 (Second edition) HSE Books 1998 ISBN 0 7176 1485 9
- *Respiratory protective equipment at work: A practical guide* HSG53 (Third edition) HSE Books 2005 ISBN 0 7176 2904 X
- *Controlling exposure to stonemasonry dust: Guidance for employers* HSG201 HSE Books 2001 ISBN 0 7176 1760 2
- *Control of respirable crystalline silica in quarries* HSG73 HSE Books 1992 ISBN 0 11 885680 4
- For environmental guidelines see sheet SL0

Useful links

- The Stone Federation may advise on health and safety consultants and training providers. Website: www.stone-federationgb.org.uk.
- For information about health and safety, or to report inconsistencies or inaccuracies in this guidance, visit www.hse.gov.uk/. You can view HSE guidance online and order priced publications from the website. HSE priced publications are also available from bookshops.
- Contact the British Occupational Hygiene Society (BOHS) on 01332 298101 or at www.bohs.org for lists of qualified hygienists who can help you.
- Look in the Yellow Pages under 'Health and safety consultants' and 'Health authorities and services' for 'occupational health'.
- Also see www.nhsplus.nhs.uk.

Employee checklist

- Are you sure how to use all dust controls?
- Is the equipment switched off and locked off for maintenance and cleaning?
- Check your RPE works properly every time you use it.
- Is the extraction working, with the guard properly adjusted?
- Look for signs of leaks, wear and damage every day.
- If you find any problems, tell your supervisor. Don't just carry on working.
- Make suggestions to improve the effectiveness of dust control.
- Co-operate with health surveillance.
- Use, maintain and store your protective equipment in accordance with instructions.
- Use skin creams provided as instructed.

This document is available at: www.hse.gov.uk/pubns/guidance/ and www.hse.gov.uk/coshh/essentials/

This document contains notes on good practice which are not compulsory but which you may find helpful in considering what you need to do.

© Crown copyright If you wish to reuse this information visit www.hse.gov.uk/copyright.htm for details. First published 10/06