

P17

Stencil generation

COSHH essentials for printers



This information is intended to help employers in the printing industry comply with the requirements of the Control of Substances

Hazardous to Health Regulations 2002 (COSHH), as amended, to control exposure to chemicals and protect workers' health.

It is also useful for trade union safety representatives.

This sheet describes good practice for making screen printing stencils. Sheet P16 covers the task of attaching the screen to its frame.

It is important to follow all the points or use equally effective measures.

Main points

- Dermatitis is common in printing. This is caused by frequent contact with chemicals used in printing processes.
- Minimise skin contact with fixers and plate developers.

Screen printing

Access and premises

- ✓ Only allow authorised staff access to the stencil generation area.
- ✓ Provide good facilities for washing, skin care, and for taking refreshments.

Equipment

- ✓ Provide splash-resistant gloves.
- ✓ Provide a good standard of general ventilation. Use powered wall- or window-mounted fans to supply fresh air - five to ten air changes per hour, with a through draught.
- ✓ Can you avoid screen repair fluids containing chlorinated solvents?
- ✓ Screen units with shutters, blinds or wraparound curtains. Position controls and switches outside the screen.

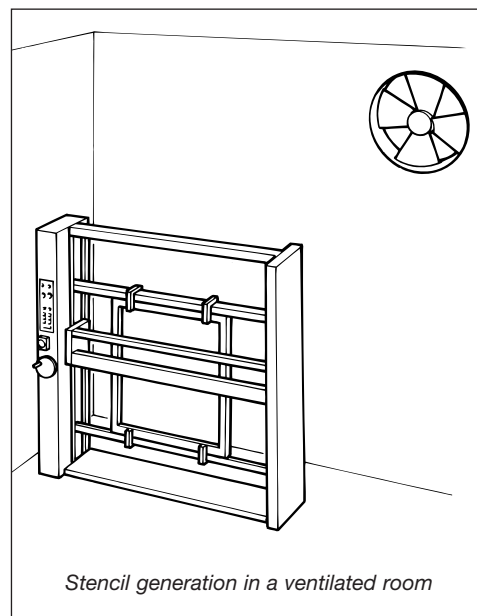

Special care

- ✓ Some photostencil products contain acrylates that can cause dermatitis.
- ✓ Screen repair products containing isocyanates can cause dermatitis and asthma.

Maintenance, examination and testing

- ✓ Follow the instructions in the maintenance manual - keep equipment in effective and efficient working order.
- ✓ Noisy or vibrating fans indicate a problem. Do repairs as necessary.

Personal protective equipment (PPE)

- ✓ Provide storage for PPE to prevent damage or contamination when not in use.

Respiratory protective equipment (RPE)

- ✓ Respiratory protective equipment should not be needed for routine use.

Gloves

- ✓ Use splash-resistant gloves - single-use nitrile gloves, 0.2 mm thick are acceptable.
- ✓ Ensure that workers wear them.
- ✓ Tell workers to dispose of single-use gloves every time they take them off.

Other protective equipment

- ✓ Eye protection.
- ✓ Impervious apron.
- ✓ Cotton overalls to minimise clothing contamination.
- ✓ Change contaminated overalls immediately and ensure they are laundered before reuse.

Skin management

- ✓ Skin contact with the chemicals may cause dermatitis.

Skin care

- ✓ Keep hands clean and in good condition.
- ✓ Using pre-work creams helps make removing chemicals easier. However, pre-work creams should not be seen as a substitute for gloves.
- ✓ If you need to use hand cleansers to remove ink, ensure that the cleanser is rinsed off afterwards.
- ✓ Provide after-work creams (moisturisers) to replace skin oils.
- ✓ Never allow solvents to be used for cleaning skin.

Skin surveillance/checks

- ✓ Consider seeking advice from an occupational health professional.
- ✓ Appoint a responsible person to carry out periodic skin inspections and record the findings.

Cleaning and housekeeping

- ✓ Keep the work area tidy, clean and free of combustible materials.
- ✓ Clean the workroom at least once a week.
- ✓ Handle containers with care and replace caps. Wipe off any liquid on the outside of the container.
- ✓ Store containers in a safe place, securely closed.
- ✓ Clean up spills immediately. Use new nitrile gloves 0.4 mm thick. Throw away gloves once used.
- ✓ Store contaminated cloths, wipes and gloves in fire-resisting, closed, metal containers. Dispose of them as hazardous waste.
- ✓ Dispose of spent emulsion, waste solvent and empty containers as hazardous waste.
- ✓ Use a contract laundry or a suitable equivalent to wash work clothing. Don't do this at home.

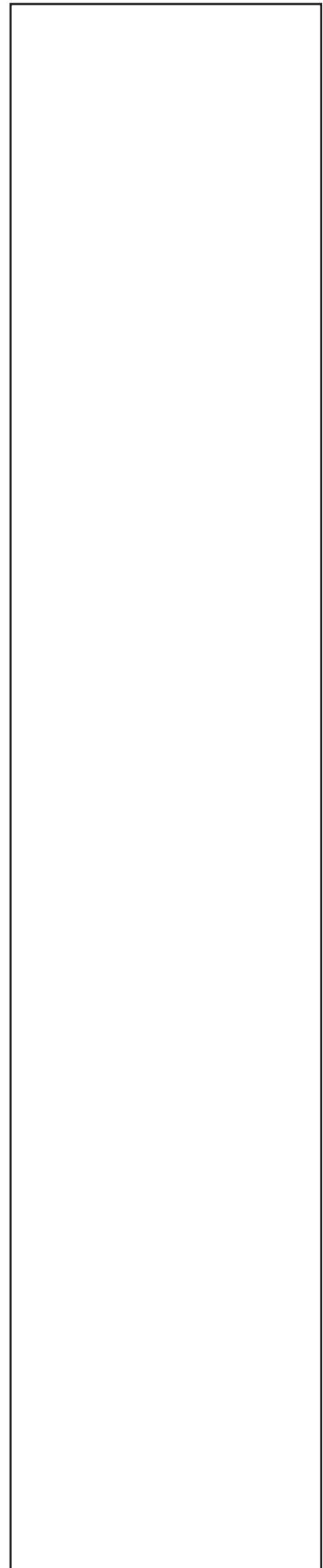

Training and supervision

- ✓ Working in the right way is important for exposure control. Train and supervise workers - see details in sheet P0.

Environmental guidelines

Releases into the air may be regulated within the Pollution Prevention and Control (PPC) framework. Your local authority or the Environment Agency will tell you if PPC applies to your company, and give advice on air cleaning and discharging emissions. In Scotland, consult the Scottish Environment Protection Agency (SEPA). For more information, see <http://www.environment-agency.gov.uk/netregs/sectors/>.

Further information

- *The printer's guide to health and safety* (Second edition)
HSE Books 2002 ISBN 0 7176 2267 3
- *Skin problems in the printing industry* Leaflet IACL101(rev1)
HSE Books 2002 (single copy free or priced packs of 15
ISBN 0 7176 2322 X)
- *General ventilation in the workplace: Guidance for employers* HSG202
HSE Books 2000 ISBN 0 7176 1793 9

Useful links

Contact the British Occupational Hygiene Society (BOHS) on 01332 298101 or at www.bohs.org/ for lists of qualified hygienists who can help you.

Look in Yellow Pages under 'Health and safety consultants' and 'Health authorities and services' for occupational physicians (doctors and nurses). Also see www.nhsplus.nhs.uk/.

Employee checklist

- Is the workroom ventilation switched on and working properly?
- Look for signs of wear and damage.
- If you find any problems, tell your supervisor or safety/employee representative. Don't just carry on working.
- Wear your protective equipment as directed.
- Don't use damaged gloves.
- Throw away single-use gloves every time you take them off.
- Never use solvents to clean your hands - only use proprietary skin cleansers.
- Use skin creams provided, as instructed.
- Check your skin regularly for dryness or soreness - tell your supervisor if these appear.
- Wash your hands before eating and drinking and before you leave work.
- Don't smoke in the work area.

This guidance is issued by the Health and Safety Executive. Following the guidance is not compulsory and you are free to take other action. But if you do follow the guidance you will normally be doing enough to comply with the law. Health and safety inspectors seek to secure compliance with the law and may refer to this guidance as illustrating good practice.