

# MN3

## COSHH essentials in manufacturing: Silica



This information will help employers (including the self-employed) comply with the Control of Substances Hazardous to Health

Regulations 2002 (COSHH), as amended, to control exposure to respirable crystalline silica (RCS) and protect workers' health.

It is also useful for trade union safety representatives.

This sheet describes good practice using RPE and dust extraction.

It covers the points you need to follow to reduce exposure to an adequate level.

It is important to follow all the points, or use equally effective measures.

### Main points

- Very high dust levels result from handling silica flour (quartz, cristobalite and mineral powders).
- Breathing in dust may cause silicosis.
- Keep exposure as low as possible using all the controls in this sheet. Make sure the controls work.
- You need air sampling. See sheet G409.
- Health surveillance is usually needed. See sheet G404.

# Dry-mixing powders containing silica

## Control approach R

### Respiratory protective equipment (RPE)

#### Hazard

- ✓ Some manufactured products contain powdered silica or mineral as an ingredient, and produce airborne respirable crystalline silica (RCS).
- ✓ All RCS is hazardous, causing silicosis. This is a serious lung disease causing permanent disability and early death.
- ✓ Silicosis is made worse by smoking.
- ✓ 'Respirable' means that the dust can get to the deepest parts of the lung. Such fine dust is invisible under normal lighting.
- ✓ Remember that drips and spills that dry off are a source of dust.
- ✓ Keep inhalation of RCS as low as possible.
- ✓ When all controls are applied properly, less than 0.1 mg/m<sup>3</sup> RCS is usually achievable (based on an 8-hour time-weighted average).

#### Crystalline silica concentrations in common materials

- ✓ Mineral powders and silica flour are common ingredients in products such as surface coatings, abrasives, plastics, grouts, mastics, ceramic glazes and investment casting media.
- ✓ Silica flour contains 100% crystalline silica. See the safety data sheet for information about concentrations in mineral powders.

#### Access and premises

- ✓ Only allow access to authorised staff.
- ✓ Floors should slope gently towards gulleys, to help dust removal by wet washing.

#### Equipment

- ✓ RPE is normally needed to reduce exposures to an acceptable level.
- ✓ Enclose the operation as much as possible.
- ✓ Keep the open face as small as possible, while giving room for safe working. Use plastic strips to reduce the open area.
- ✓ Locate the booth away from doors, windows and walkways to stop draughts interfering with the extraction.

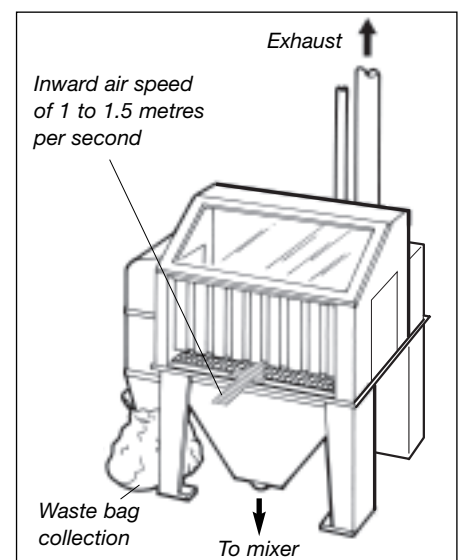

- ✓ You need an inward air speed between 1 and 1.5 metres per second at the face of the extracted enclosure.
- ✓ Fit a manometer or pressure gauge near the extraction point, to show that the system is working properly.
- ✓ Mark the acceptable range of readings.
- ✓ Discharge cleaned, extracted air to a safe place outside, away from doors, windows and air inlets.
- ✓ Have a supply of clean air coming into the workroom to replace extracted air.
- ✓ Fit an indicator or alarm to show if filters have blocked or failed.
- ✓ Consult a qualified ventilation engineer to design new control systems or to update current controls. See sheet G406.

### *Procedures*

- ✓ Always confirm that the dust extraction is turned on and working before starting work.
- ✓ Make sure that workers check that their RPE works properly every time they put it on.
- ✓ Clean air pre-filters daily, or follow the manufacturer's advice.
- ✓ Shake down air filters regularly (eg every hour), or use automated reverse-jet cleaning.
- ✓ Make sure you can get spares easily.

### **Maintenance, examination and testing**

- ✓ Minerals and silica-containing dusts are very abrasive. Plan regular maintenance.
- ✓ Follow instructions in maintenance manuals - keep equipment in effective and efficient working order.
- ✓ Clean down the equipment before starting maintenance - use wet or dustless methods.
- ✓ If the dust extraction or filtration plant is faulty, stop work until it is repaired.
- ✓ Daily, look for signs of damage. Noisy or vibrating fans can indicate a problem.
- ✓ At least once a week, check that the dust extraction system and gauges work properly.
- ✓ Check that filter seatings are in good condition.
- ✓ You need to keep all controls in good working order. See sheet G406 for advice on engineering controls.
- ✓ You need to know the manufacturer's specifications to check the extraction's performance.
- ✓ If this information isn't available, hire a competent ventilation engineer to determine the performance needed for effective control.
- ✓ The engineer's report must show the target extraction rates.
- ✓ Keep this information in your testing log-book.
- ✓ Get a competent ventilation engineer to examine the extraction thoroughly and test its performance at least once every 14 months. See the HSE publication HSG54 - see 'Further information'.
- ✓ Examine and test RPE thoroughly at least once every three months.
- ✓ Keep records of all examinations and tests for at least five years.

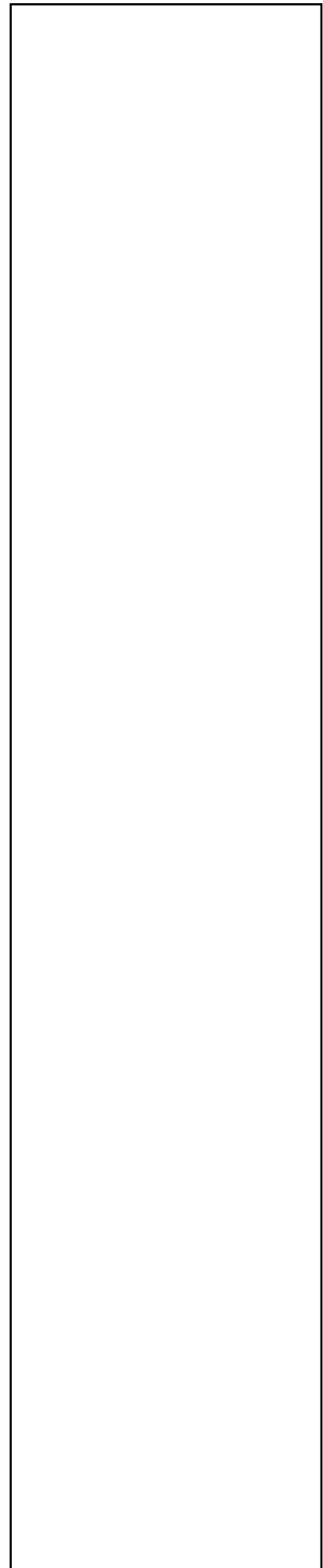

- 
- ✓ Review records - failure patterns show where preventive maintenance is needed.
  - ✓ Make sure that users examine their RPE thoroughly and test it works properly every time they use it.
  - ✓ Keep records of these tests.
  - ✓ Carry out air sampling to check that the controls are working well. See sheet G409.

### Personal protective equipment (PPE)

- ✓ Ask your supplier to help you select the right PPE.
- ✓ Provide storage for clean and for contaminated PPE.

### Respiratory protective equipment (RPE)

- ✓ RPE is normally needed.
- ✓ RPE is often needed for maintenance and some cleaning jobs.
- ✓ Powered or air-fed RPE is more comfortable to wear.
- ✓ Select RPE that suits the wearer, the job and the work environment.
- ✓ Decide the level of protection from air sampling data. Otherwise, use RPE with an assigned protection factor (APF) of at least 10. See sheet R2.
- ✓ Disposable RPE is acceptable.
- ✓ Make sure all RPE is properly fit-tested - get advice from your supplier.
- ✓ Replace RPE filters as recommended by the supplier. Throw away disposable RPE at the end of the job or the end of the shift.
- ✓ Keep RPE clean.

### Other protective equipment

- ✓ Provide coveralls that do not retain dust. Use synthetic fabrics - not cotton or knitted.
- ✓ Use a contract laundry or a suitable equivalent to wash work clothing. Warn them that the dust contains silica.
- ✓ Skin creams help in washing contamination from the skin. After-work creams help to replace skin oils.

**Caution: Never allow use of compressed air for removing dust from clothing.**

### Health surveillance

- ✓ You need health surveillance unless exposure to RCS is well below the limit. See sheet G404.
- ✓ Consult an occupational health professional - see 'Useful links'.

### Cleaning and housekeeping

- ✓ Clean down the enclosure and equipment as soon as possible after use.
- ✓ Wash down the workroom at the end of each day's work.
- ✓ Damp down and shovel large amounts carefully to avoid stirring up dust. Provide RPE.
- ✓ Use a Type H vacuum cleaner fitted with a HEPA filter to clear up dust, eg on overhead fittings.

**Caution: Don't use a brush or compressed air.**

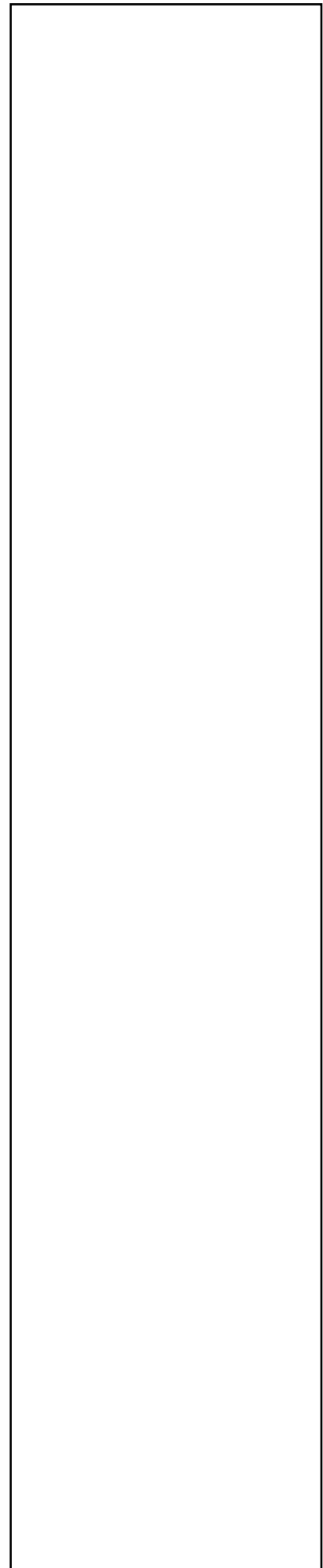

### Training and supervision

- ✓ Tell workers that silica dust can cause serious lung diseases.
- ✓ Working in the right way and using the controls correctly is important for exposure control. Train and supervise workers. See sheet MN0.

### Further information

- *Dust control in powder handling and weighing: A revised COSHH guide* Guidance HSE Books 1997 ISBN 0 7176 1370 4
- *Maintenance, examination and testing of local exhaust ventilation* HSG54 (Second edition) HSE Books 1998 ISBN 0 7176 1485 9
- *Respiratory protective equipment at work: A practical guide* HSG53 (Third edition) HSE Books 2005 ISBN 0 7176 2904 X
- For environmental guidelines see sheet CNO

### Useful links

- For information about health and safety, or to report inconsistencies or inaccuracies in this guidance, visit [www.hse.gov.uk/](http://www.hse.gov.uk/). You can view HSE guidance online and order priced publications from the website. HSE priced publications are also available from bookshops.
- Contact the British Occupational Hygiene Society (BOHS) on 01332 298101 or at [www.bohs.org](http://www.bohs.org) for lists of qualified hygienists who can help you.
- Look in the Yellow Pages under 'Health and safety consultants' and 'Health authorities and services' for 'occupational health'.
- Also see [www.nhsplus.nhs.uk](http://www.nhsplus.nhs.uk).

This document is available at: [www.hse.gov.uk/pubns/guidance/](http://www.hse.gov.uk/pubns/guidance/) and [www.hse.gov.uk/coshh/essentials/](http://www.hse.gov.uk/coshh/essentials/)

**This document contains notes on good practice which are not compulsory but which you may find helpful in considering what you need to do.**

© Crown copyright If you wish to reuse this information visit [www.hse.gov.uk/copyright.htm](http://www.hse.gov.uk/copyright.htm) for details. First published 10/06

### Employee checklist

- Are you sure how to use all dust controls?
- Check your RPE works properly every time you use it.
- Is the dust extraction working? Check the gauge.
- Look for signs of leaks, wear and damage every day.
- If you find any problems, tell your supervisor. Don't just carry on working.
- Clear up dust spills promptly.
- Make suggestions to improve the effectiveness of dust control.
- Co-operate with health surveillance.
- Use, maintain and store your protective equipment in accordance with instructions.
- Use skin creams provided as instructed.