

AG3

COSHH essentials for farmers

This information will help employers, the self-employed and contractors comply with the Control of Substances Hazardous to Health Regulations 2002 (COSHH), as amended, to control exposure and protect workers' health.

It is also useful for trade union safety representatives.

This sheet describes good practice using dust extraction.

It covers the key points you need to follow to help reduce exposure to an adequate level.

It is important to follow all the points, or use equally effective measures.

Main points

- High dust levels are produced when mixing animal feed.
- Keep exposure as low as possible using all the controls in this sheet.
- Health surveillance is usually needed - see sheet G402.

Weighing, milling and mixing animal feeds

Control approach 2 Engineering control

Hazard

- ✓ Dust produced by moving and processing grain and seed contains bacteria, fungi and insect residues, and can cause lung diseases such as asthma and farmer's lung. Enzyme additives may cause asthma.
- ✓ Control exposure to stop occupational lung diseases developing - this means short-term as well as long-term exposure.
- ✓ When all controls are applied properly, less than 10 mg/m³ grain dust is usually achievable (based on an 8-hour time weighted average).
- ✓ If an individual develops occupational asthma, avoid further exposure.

Access and premises

- ✓ Only allow access to trained people. Do people need to be present during milling?
- ✓ Place the machinery controls outside the area and an emergency stop near the machine.
- ✓ In larger plant, provide a separate control room.

Equipment and procedures

- ✓ Provide a good standard of general ventilation; 5-10 air changes per hour, with a through draught.
- ✓ Avoid weighing out. Can you buy additives in one-shot packages?
- ✓ Can you suppress dust by using molasses or oil in the feed formula?
- ✓ Use enclosed or extracted elevators and conveyors.
- ✓ Fit lids where dust can escape, and enclose chutes. Can you auger the mixed feed to storage bins?
- ✓ Fit the hopper, mixer and bagging-off point with dust extraction.
- ✓ You need an inward air speed between 1 and 2.5 metres per second into the openings.
- ✓ Fit manometers or pressure gauges near extraction points, to show that the system is working properly.
- ✓ Mark the acceptable range of readings.
- ✓ Keep extraction ducts short and simple - avoid long sections of flexible duct.
- ✓ If possible, discharge cleaned, extracted air to a safe place outside, away from doors, windows and air inlets.
- ✓ If you cannot avoid breathing dust, use respiratory protective equipment (RPE).

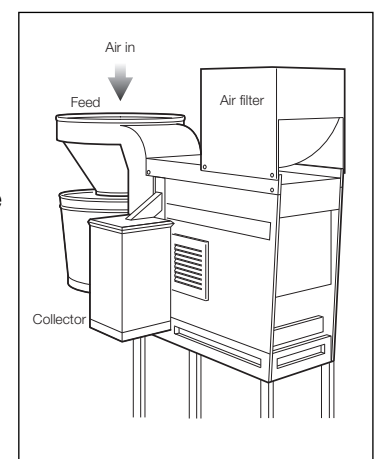

- ✓ Consult a qualified ventilation engineer to design new control systems or to update current controls. See sheet G406.

Caution: Some dusts (eg from barley) are very irritating to skin.

Special care

- ✓ Very small amounts of enzyme additive can cause asthma.

Respiratory Protective Equipment (RPE)

- ✓ RPE should not be needed if the extraction works properly and dust enclosures are sound.
- ✓ RPE is needed for maintenance and cleaning inside the machinery.
- ✓ Powered or air-fed RPE is more comfortable to wear.
- ✓ Select RPE that suits the wearer, the job and the work environment.
- ✓ Use RPE with an assigned protection factor (APF) of at least 10. See sheet R2.
- ✓ Disposable RPE, type FFP2, is acceptable. Don't use 'nuisance dust' masks.
- ✓ Make sure that RPE fits properly - get advice from your supplier or read the instructions on the box.
- ✓ Train workers to check their RPE works properly before use.
- ✓ Replace RPE filters as recommended by the supplier. Throw away disposable RPE at the end of the day, or sooner if heavily soiled.
- ✓ Keep RPE clean and store it away from dust.

Maintenance, examination and testing

- ✓ Follow instructions in maintenance manuals - keep equipment in effective and efficient working order.
- ✓ Every time you use the equipment, look for signs of damage, eg to ducts and seals. Noisy or vibrating fans indicate a problem.
- ✓ Check that dust extraction and gauges work properly.
- ✓ If the extraction is faulty, use RPE until it is repaired and for carrying out repairs.
- ✓ You need to know the manufacturer's specifications to check the extraction's performance.
- ✓ If this information isn't available, hire a competent ventilation engineer to determine the performance needed for effective control.
- ✓ The engineer's report must show the target extraction rates.
- ✓ Keep this information in your testing log-book.
- ✓ Get a competent ventilation engineer to examine the extraction thoroughly and test its performance at least once every 14 months. See the HSE publication HSG54 - see 'Further information'.
- ✓ Examine and test non-disposable RPE thoroughly at least once every three months.
- ✓ Keep records of all examinations and tests for at least five years.
- ✓ Review records - failure patterns show where preventive maintenance is needed.

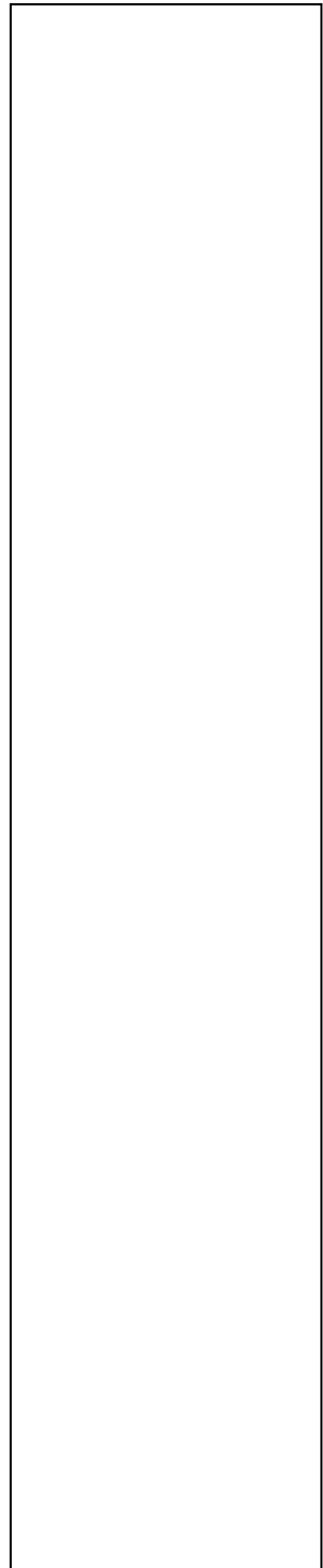

Cleaning and housekeeping

- ✓ At least once a day, clear up waste.
- ✓ Use gentle shovelling and a Type H vacuum cleaner fitted with a HEPA filter, or wet clean to avoid stirring up dust.
- ✓ Store empty bags outside the workroom.
Caution: Don't use a brush or compressed air, and never use compressed air to remove dust from clothing.

Health surveillance

- ✓ There is a chance of asthma developing, even with good controls in place. Use health surveillance - see Sheet G402.
- ✓ Ask an occupational physician for advice - see 'Useful links'

Training and supervision

- ✓ Tell workers that grain and additive dust can cause lung diseases including asthma. Show them this sheet.
- ✓ Working in the right way and using the controls correctly is important for exposure control. Train and supervise workers. See sheet AG0.
- ✓ Ensure that health surveillance is carried out on everyone that needs it.

Further information

- *Maintenance, examination and testing of local exhaust ventilation* HSG54 (Second edition) HSE Books 1998 ISBN 0 7176 1485 9
- *Preventing asthma at work. How to control respiratory sensitisers* L55 HSE Books 1994 ISBN 0 7176 0661 9
- *Farmer's lung* Agricultural Safety Leaflet AS5 HSE Books 1995
- *Controlling grain dust on farms* Agriculture Information Sheet AIS3(rev) HSE Books 1996
- See www.hse.gov.uk/pubns/agindex.htm for other advice on health and safety risks in agriculture.

Useful links

- For information about health and safety, or to report inconsistencies or inaccuracies in this guidance, visit www.hse.gov.uk/. You can view HSE guidance online and order priced publications from the website. HSE priced publications are also available from bookshops.
- Contact the British Occupational Hygiene Society (BOHS) on 01332 298101 or at www.bohs.org for lists of qualified hygienists who can help you.

This document is available at: www.hse.gov.uk/pubns/guidance/ and

This document contains notes on good practice which are not compulsory but which you may find helpful in considering what you need to do.

© Crown copyright If you wish to reuse this information visit www.hse.gov.uk/copyright.htm for details. First published 12/06

Employee checklist

- Do you know how to use the dust controls properly?
- Is the extraction working?
- Look for signs of leaks, wear and damage.
- If you find any problems, get them fixed. Don't just carry on working.
- Co-operate with health surveillance.